

# TUFFALOY

Resistance Welding Products

Serving the Resistance Welding Industry Since 1937



## 2021 PRODUCT CATALOG

# QUOTE REQUEST SPECIALS AND CUSTOMS

Contact Name: \_\_\_\_\_ Company: \_\_\_\_\_

Address: \_\_\_\_\_

Phone: \_\_\_\_\_ Fax: \_\_\_\_\_ Email: \_\_\_\_\_

Part Information: \_\_\_\_\_ Material/Alloy: \_\_\_\_\_

Part Number or Description: \_\_\_\_\_

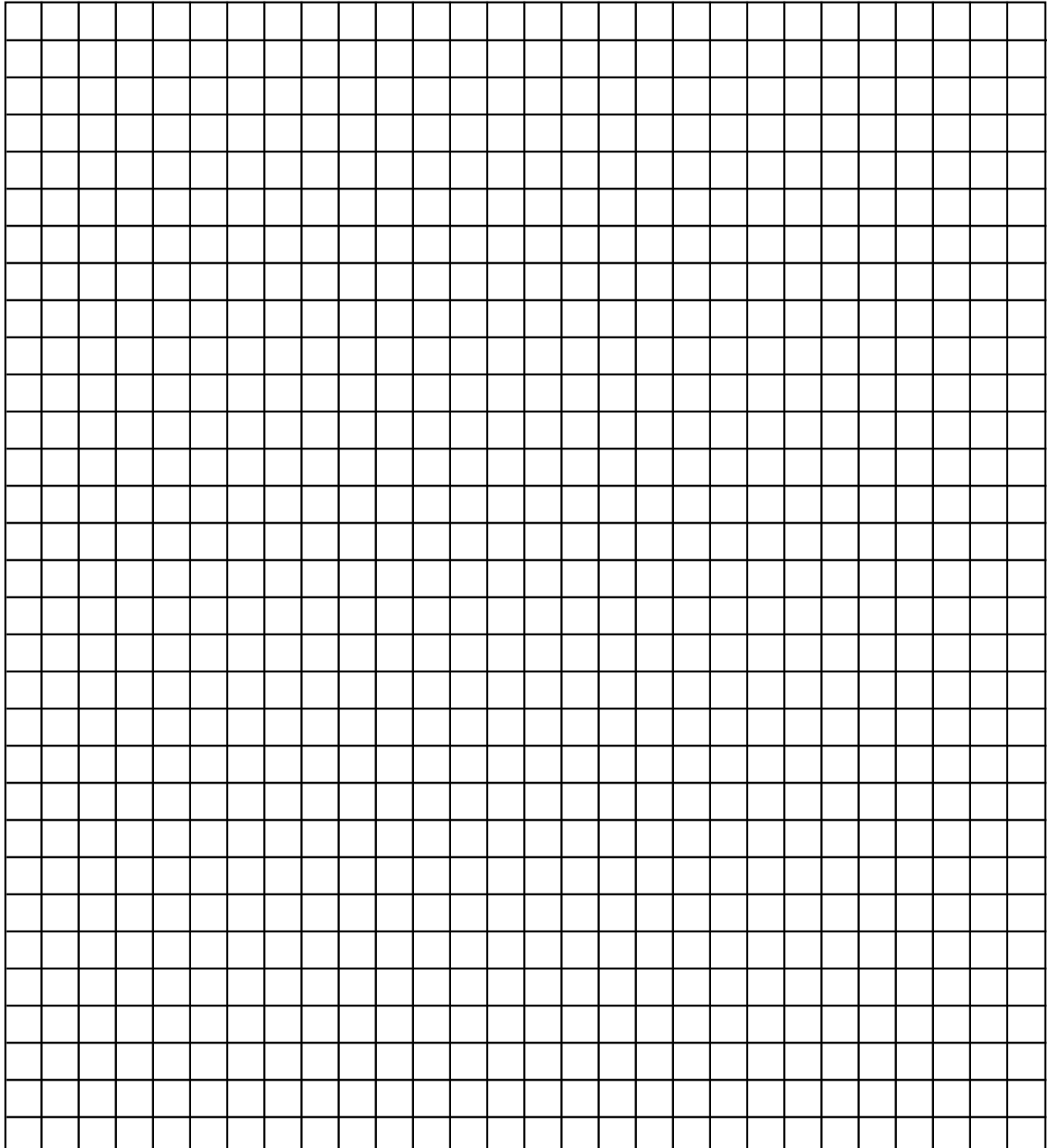

Please send a photo of part laying on the grid area of this completed page to – [customerservice@tuffaloy.com](mailto:customerservice@tuffaloy.com)



## **RESISTANCE WELDING PRODUCTS**

The little “**TUFFALOY man**” is now over eighty years old. It was in 1937 that Welding Sales & Engineering Company of Detroit introduced a new line of resistance welding alloys tradenamed TUFFALOY. What began as just a part of a general line of welding equipment soon became their main business, as electrode holders and other resistance welding accessories were added to the TUFFALOY product line. Today this now-familiar name represents the most innovative and respected resistance welding alloy and accessory company in the field.

Even a catalog as comprehensive as this one does not fully show everything TUFFALOY is capable of supplying. In addition to the standard products in this catalog, TUFFALOY manufactures 1,000s of SKUs annually that are specially designed for unique customer applications. So, if you don't find the exact parts in these pages, tell us what you're looking for and let us work with you in designing the part to solve your resistance welding needs.

Find Tuffaloy Distributors at;  
**TUFFALOY.COM/DISTRIBUTORS**

Or

Contact Tuffaloy Customer Service at;  
**CUSTOMERSERVICE@TUFFALOY.COM**

Phone: (800) 521-3722 or (864) 879-0763

Fax: (864) 877-2212









For the most complete and up to date product offering, please visit us at;  
**TUFFALOY.COM**









**WARNING:** Products identified herein may expose you to chemicals known to the State of California to cause cancer and/or birth defects or other reproductive harm. For more information go to [www.p65warnings.ca.gov](http://www.p65warnings.ca.gov) Before purchasing any product identified therein, please consult the product display page of that product on [www.tuffaloy.com](http://www.tuffaloy.com) to review any product-specific warning.



## STANDARD ELECTRODES

	<a href="#">Straight Tips</a>	Page 4
	<a href="#">TUFFCAP Caps and Shanks</a>	Page 7
	<a href="#">Standard Bent Electrodes</a>	Page 10
	<a href="#">Miscellaneous Electrodes</a>	Page 12
	<a href="#">Back Up Electrodes</a>	Page 14
	<a href="#">Swivel Tips</a>	Page 15
	<a href="#">Refractory Metal-Faced Tips</a>	Page 15
	<a href="#">Threaded Electrodes</a>	Page 16

## WELDING ELECTRODE HOLDERS

	<a href="#">Electrode Adapters</a>	Page 17
	<a href="#">Cylinder-Mounted Holders</a>	Page 18
	<a href="#">Multi-Spot Barrel and Clamp</a>	Page 19
	<a href="#">Straight Holders</a>	Page 20
	<a href="#">Offset Holders</a>	Page 24
	<a href="#">Welder Arms</a>	Page 24
	<a href="#">Variable Offset Holders</a>	Page 26









## WELDING ELECTRODE HOLDERS (continued)

	<a href="#">Paddle-Type Holders</a>	Page 27
	<a href="#">Platen-Mounted Holders</a>	Page 30
	<a href="#">Fast Follow-Up Holders</a>	Page 42

## HIGH PRESSURE WELDING

	<a href="#">Electrodes and Holders</a>	Page 28
---	--	---------





## NUT AND STUD WELDING

	<a href="#">Platen Mount Nut and Stud Holders</a>	Page 30
	<a href="#">Nut Welding Electrodes</a>	Page 31
	<a href="#">Nut Welding Electrode Holders</a>	Page 32
	<a href="#">Arctic Nut and Stud Welding Water Cooled</a>	Page 32
	<a href="#">Metric Nut Electrode Systems</a>	Page 33
	<a href="#">GH Series Nut Welding Head</a>	Page 34
	<a href="#">Stainless Steel Pins for GH Head Style Welding</a>	Page 35
	<a href="#">Stud and Backup Welding Electrodes</a>	Page 36



# TUFFALOY TABLE OF CONTENTS





## MULTIPLE WELDING

	<a href="#">Teeter Tip Adapters</a>	<a href="#">Page 37</a>
	<a href="#">Equatip Dual Tip Holders</a>	<a href="#">Page 38</a>
	<a href="#">Equa-Press Dual Tip Holders</a>	<a href="#">Page 39</a>
	<a href="#">Trispacer Triple Tip Holder</a>	<a href="#">Page 41</a>

## RESISTANCE WELDING ALLOYS

	<a href="#">Bar Stock</a>	<a href="#">Page 44</a>
	<a href="#">Refractory Metals and Forgings</a>	<a href="#">Page 45</a>



## ACCESSORIES

	<a href="#">Shunts and Cables</a>	<a href="#">Page 46</a>
	<a href="#">Stationary Water Tubes</a>	<a href="#">Page 18</a>
	<a href="#">Electrode Taper Reamers Tap and TUFFCAP Taper Reamers</a>	<a href="#">Page 47</a>
	<a href="#">Tip Dressing Tool</a>	<a href="#">Page 47</a>
	<a href="#">Radius File</a>	<a href="#">Page 47</a>
	<a href="#">Welding Tip Extractors</a>	<a href="#">Page 47</a>
	<a href="#">TUFFCAP Extractors</a>	<a href="#">Page 47</a>
	<a href="#">Quick Connect Couplings</a>	<a href="#">Page 47</a>

## ACCESSORIES (continued)

	<a href="#">Conductive Lube</a>	<a href="#">Page 47</a>
	<a href="#">Water Hose Connectors and Clamps</a>	<a href="#">Page 47</a>
	<a href="#">Weld Analyzer</a>	<a href="#">Page 48</a>
	<a href="#">Weld Force Gauges</a>	<a href="#">Page 50</a>
	<a href="#">Pneumatic Electrode Dresser</a>	<a href="#">Page 52</a>

## MISCELLANEOUS

	<a href="#">Welder Arms</a>	<a href="#">Page 24</a>
	<a href="#">Seam Welding Wheels and Forging</a>	<a href="#">Page 45</a>
	<a href="#">Resistance Welding Alloys</a>	<a href="#">Page 53</a>
	<a href="#">Properties For RWMA Alloys</a>	<a href="#">Page 54</a>
	<a href="#">Recommended Electrode Materials</a>	<a href="#">Page 55</a>
	<a href="#">Electrode Maintenance</a>	<a href="#">Page 56</a>
	<a href="#">Schedules for Spot Welding</a>	<a href="#">Page 57</a>
	<a href="#">Weld Defects and Causes</a>	<a href="#">Page 61</a>
	<a href="#">Helpful Data Suggestions</a>	<a href="#">Page 62</a>

### SAFETY DATA SHEETS

[www.tuffaloy.com/technical/sds](http://www.tuffaloy.com/technical/sds)



# TUFFALOY STANDARD STRAIGHT TIPS

Straight tips from TUFFALOY are distinguished by their high conductivity and resistance to deformation, which are the two critical requirements of resistance welding tips. We ensure conformity to all RWMA standard dimensions and before shipment, all tips must pass rigorous quality control inspections.

## TAPER ENGAGEMENT

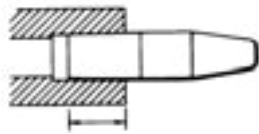

TIP SIZE	LENGTH
4 RW	1/2-in.
5 RW	3/4-in.
6 RW	7/8-in.
7 RW	1-1/8-in.

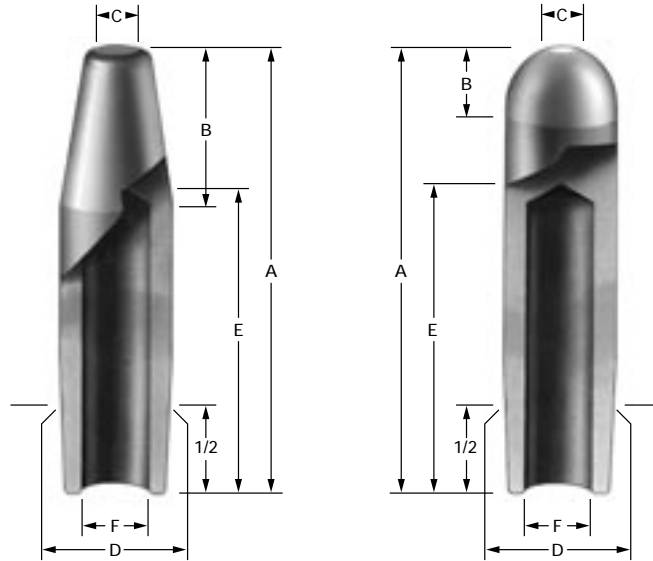

## 'A' POINTED NOSE

## 'B' DOME NOSE

A	C	D	E	F
Overall Length	Welding Face Dia.	Gauging Dia.	Water Hole Depth	Water Hole Dia.

### NO. 4 RW TAPER - 1/2" DIAMETER

1	3/16	.463	1/2	9/32
1-1/4	3/16	.463	3/4	9/32
1-1/2	3/16	.463	1	9/32
1-3/4	3/16	.463	1-1/4	9/32
2	3/16	.463	1-1/2	9/32
2-1/4	3/16	.463	1-3/4	9/32
2-1/2	3/16	.463	2	9/32
2-3/4	3/16	.463	2-1/4	9/32
3	3/16	.463	2-1/2	9/32
3-1/4	3/16	.463	2-3/4	9/32
3-1/2	3/16	.463	3	9/32
3-3/4	3/16	.463	3-1/4	9/32
4	3/16	.463	3-1/2	9/32

B Nose Length	RWMA CLASS 1		RWMA CLASS 2	
	Description	Part No.	Description	Part No.

3/8	A-1404	131-1404	A-2404	132-2404
3/4	A-1405	131-1405	A-2405	132-2405
3/4	A-1406	131-1406	A-2406	132-2406
3/4	A-1407	131-1407	A-2407	132-2407
3/4	A-1408	131-1408	A-2408	132-2408
3/4	A-1409	131-1409	A-2409	132-2409
3/4	A-1410	131-1410	A-2410	132-2410
3/4	A-1411	131-1411	A-2411	132-2411
3/4	A-1412	131-1412	A-2412	132-2412
3/4	A-1413	131-1413	A-2413	132-2413
3/4	A-1414	131-1414	A-2414	132-2414
3/4	A-1415	131-1415	A-2415	132-2415
3/4	A-1416	131-1416	A-2416	132-2416

B Nose Length	RWMA CLASS 1		RWMA CLASS 2	
	Description	Part No.	Description	Part No.

1/4	B-1404	133-1404	B-2404	134-2404
1/4	B-1405	133-1405	B-2405	134-2405
1/4	B-1406	133-1406	B-2406	134-2406
1/4	B-1407	133-1407	B-2407	134-2407
1/4	B-1408	133-1408	B-2408	134-2408
1/4	B-1409	133-1409	B-2409	134-2409
1/4	B-1410	133-1410	B-2410	134-2410
1/4	B-1411	133-1411	B-2411	134-2411
1/4	B-1412	133-1412	B-2412	134-2412
1/4	B-1413	133-1413	B-2413	134-2413
1/4	B-1414	133-1414	B-2414	134-2414
1/4	B-1415	133-1415	B-2415	134-2415
1/4	B-1416	133-1416	B-2416	134-2416

### NO. 5 RW TAPER - 5/8" DIAMETER

1-1/4	1/4	.613	3/4	3/8
1-1/2	1/4	.613	3/4	3/8
1-3/4	1/4	.613	1	3/8
2	1/4	.613	1-1/4	3/8
2-1/4	1/4	.613	1-1/2	3/8
2-1/2	1/4	.613	1-3/4	3/8
2-3/4	1/4	.613	2	3/8
3	1/4	.613	2-1/4	3/8
3-1/4	1/4	.613	2-1/2	3/8
3-1/2	1/4	.613	2-3/4	3/8
3-3/4	1/4	.613	3	3/8
4	1/4	.613	3-1/4	3/8

1/2	A-1505	131-1505	A-2505	132-2505
7/8	A-1506	131-1506	A-2506	132-2506
7/8	A-1507	131-1507	A-2507	132-2507
7/8	A-1508	131-1508	A-2508	132-2508
7/8	A-1509	131-1509	A-2509	132-2509
7/8	A-1510	131-1510	A-2510	132-2510
7/8	A-1511	131-1511	A-2511	132-2511
7/8	A-1512	131-1512	A-2512	132-2512
7/8	A-1513	131-1513	A-2513	132-2513
7/8	A-1514	131-1514	A-2514	132-2514
7/8	A-1515	131-1515	A-2515	132-2515
7/8	A-1516	131-1516	A-2516	132-2516

3/8	B-1505	133-1505	B-2505	134-2505
3/8	B-1506	133-1506	B-2506	134-2506
3/8	B-1507	133-1507	B-2507	134-2507
3/8	B-1508	133-1508	B-2508	134-2508
3/8	B-1509	133-1509	B-2509	134-2509
3/8	B-1510	133-1510	B-2510	134-2510
3/8	B-1511	133-1511	B-2511	134-2511
3/8	B-1512	133-1512	B-2512	134-2512
3/8	B-1513	133-1513	B-2513	134-2513
3/8	B-1514	133-1514	B-2514	134-2514
3/8	B-1515	133-1515	B-2515	134-2515
3/8	B-1516	133-1516	B-2516	134-2516

### NO. 6 RW TAPER - 3/4" DIAMETER

2	9/32	.731	1-1/4	7/16
2-1/2	9/32	.731	1-3/4	7/16
3	9/32	.731	2-1/4	7/16
3-1/2	9/32	.731	2-3/4	7/16
4	9/32	.731	3-1/4	7/16

1	A-1608	131-1608	A-2608	132-2608
1	A-1610	131-1610	A-2610	132-2610
1	A-1612	131-1612	A-2612	132-2612
1	A-1614	131-1614	A-2614	132-2614
1	A-1616	131-1616	A-2616	132-2616

3/8	B-1608	133-1608	B-2608	134-2608
3/8	B-1610	133-1610	B-2610	134-2610
3/8	B-1612	133-1612	B-2612	134-2612
3/8	B-1614	133-1614	B-2614	134-2614
3/8	B-1616	133-1616	B-2616	134-2616

### NO. 7 RW TAPER - 7/8" DIAMETER

2	5/16	.844	1-1/4	1/2
2-1/2	5/16	.844	1-3/4	1/2
3	5/16	.844	2-1/4	1/2
3-1/2	5/16	.844	2-3/4	1/2
4	5/16	.844	3-1/2	1/2

1-1/8	A-1708	131-1708	A-2708	132-2708
1-1/8	A-1710	131-1710	A-2710	132-2710
1-1/8	A-1712	131-1712	A-2712	132-2712
1-1/8	A-1714	131-1714	A-2714	132-2714
1-1/8	A-1716	131-1716	A-2716	132-2716

3/8	B-1708	133-1708	B-2708	134-2708
3/8	B-1710	133-1710	B-2710	134-2710
3/8	B-1712	133-1712	B-2712	134-2712
3/8	B-1714	133-1714	B-2714	134-2714
3/8	B-1716	133-1716	B-2716	134-2716



The bright shiny look of TUFFALOY tips is the result of a passivation process that eliminates excessive oxidation. It reflects the deep-down quality built into these tips and into all TUFFALOY products.

Only RWMA Class 1 (C15000) and Class 2 (C18200) alloy tips are listed here. Class 3 (C18000) alloy tips are also available. For recommended uses of these alloys, see [page 53](#).

To order Class 3 (C18000) alloy tips, change description code to indicate it: see "Key to Description", [page 6](#).

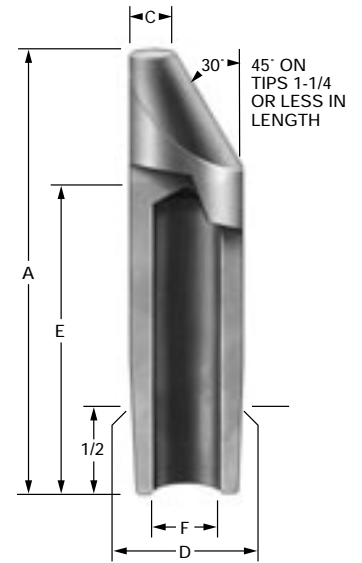
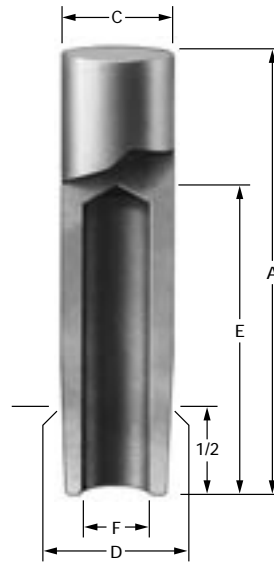

**'C' FLAT NOSE**

**'D' OFFSET NOSE**

A Overall Length	D Gauging Dia.	E Water Hole Depth	F Water Hole Dia.
------------------------	----------------------	--------------------------	-------------------------

**NO. 4 RW TAPER - 1/2" DIAMETER**

1	.463	1/2	9/32
1-1/4	.463	3/4	9/32
1-1/2	.463	1	9/32
1-3/4	.463	1-1/4	9/32
2	.463	1-1/2	9/32
2-1/4	.463	1-3/4	9/32
2-1/2	.463	2	9/32
2-3/4	.463	2-1/4	9/32
3	.463	2-1/2	9/32
3-1/4	.463	2-3/4	9/32
3-1/2	.463	3	9/32
3-3/4	.463	3-1/4	9/32
4	.463	3-1/2	9/32

C Welding Face Dia.	RWMA CLASS 1		RWMA CLASS 2	
	Descrip- tion	Part No.	Descrip- tion	Part No.

1/2	C-1404	135-1404	C-2404	136-2404
1/2	C-1405	135-1405	C-2405	136-2405
1/2	C-1406	135-1406	C-2406	136-2406
1/2	C-1407	135-1407	C-2407	136-2407
1/2	C-1408	135-1408	C-2408	136-2408
1/2	C-1409	135-1409	C-2409	136-2409
1/2	C-1410	135-1410	C-2410	136-2410
1/2	C-1411	135-1411	C-2411	136-2411
1/2	C-1412	135-1412	C-2412	136-2412
1/2	C-1413	135-1413	C-2413	136-2413
1/2	C-1414	135-1414	C-2414	136-2414
1/2	C-1415	135-1415	C-2415	136-2415
1/2	C-1416	135-1416	C-2416	136-2416

C Welding Face Dia.	RWMA CLASS 1		RWMA CLASS 2	
	Descrip- tion	Part No.	Descrip- tion	Part No.

3/16	D-1404	137-1404	D-2404	138-2404
3/16	D-1405	137-1405	D-2405	138-2405
3/16	D-1406	137-1406	D-2406	138-2406
3/16	D-1407	137-1407	D-2407	138-2407
3/16	D-1408	137-1408	D-2408	138-2408
3/16	D-1409	137-1409	D-2409	138-2409
3/16	D-1410	137-1410	D-2410	138-2410
3/16	D-1411	137-1411	D-2411	138-2411
3/16	D-1412	137-1412	D-2412	138-2412
3/16	D-1413	137-1413	D-2413	138-2413
3/16	D-1414	137-1414	D-2414	138-2414
3/16	D-1415	137-1415	D-2415	138-2415
3/16	D-1416	137-1416	D-2416	138-2416

**NO. 5 RW TAPER - 5/8" DIAMETER**

1-1/4	.613	3/4	3/8
1-1/2	.613	3/4	3/8
1-3/4	.613	1	3/8
2	.613	1-1/4	3/8
2-1/4	.613	1-1/2	3/8
2-1/2	.613	1-3/4	3/8
2-3/4	.613	2	3/8
3	.613	2-1/4	3/8
3-1/4	.613	2-1/2	3/8
3-1/2	.613	2-3/4	3/8
3-3/4	.613	3	3/8
4	.613	3-1/4	3/8

5/8	C-1505	135-1505	C-2505	136-2505
5/8	C-1506	135-1506	C-2506	136-2506
5/8	C-1507	135-1507	C-2507	136-2507
5/8	C-1508	135-1508	C-2508	136-2508
5/8	C-1509	135-1509	C-2509	136-2509
5/8	C-1510	135-1510	C-2510	136-2510
5/8	C-1511	135-1511	C-2511	136-2511
5/8	C-1512	135-1512	C-2512	136-2512
5/8	C-1513	135-1513	C-2513	136-2513
5/8	C-1514	135-1514	C-2514	136-2514
5/8	C-1515	135-1515	C-2515	136-2515
5/8	C-1516	135-1516	C-2516	136-2516

1/4	D-1505	137-1505	D-2505	138-2505
1/4	D-1506	137-1506	D-2506	138-2506
1/4	D-1507	137-1507	D-2507	138-2507
1/4	D-1508	137-1508	D-2508	138-2508
1/4	D-1509	137-1509	D-2509	138-2509
1/4	D-1510	137-1510	D-2510	138-2510
1/4	D-1511	137-1511	D-2511	138-2511
1/4	D-1512	137-1512	D-2512	138-2512
1/4	D-1513	137-1513	D-2513	138-2513
1/4	D-1514	137-1514	D-2514	138-2514
1/4	D-1515	137-1515	D-2515	138-2515
1/4	D-1516	137-1516	D-2516	138-2516

**NO. 6 RW TAPER - 3/4" DIAMETER**

2	.731	1-1/4	7/16
2-1/2	.731	1-3/4	7/16
3	.731	2-1/4	7/16
3-1/2	.731	2-3/4	7/16
4	.731	3-1/4	7/16

3/4	C-1608	135-1608	C-2608	136-2608
3/4	C-1610	135-1610	C-2610	136-2610
3/4	C-1612	135-1612	C-2612	136-2612
3/4	C-1614	135-1614	C-2614	136-2614
3/4	C-1616	135-1616	C-2616	136-2616

9/32	D-1608	137-1608	D-2608	138-2608
9/32	D-1610	137-1610	D-2610	138-2610
9/32	D-1612	137-1612	D-2612	138-2612
9/32	D-1614	137-1614	D-2614	138-2614
9/32	D-1616	137-1616	D-2616	138-2616

**NO. 7 RW TAPER - 7/8" DIAMETER**

2	.844	1-1/4	1/2
2-1/2	.844	1-3/4	1/2
3	.844	2-1/4	1/2
3-1/2	.844	2-3/4	1/2
4	.844	3-1/2	1/2

7/8	C-1708	135-1708	C-2708	136-2708
7/8	C-1710	135-1710	C-2710	136-2710
7/8	C-1712	135-1712	C-2712	136-2712
7/8	C-1714	135-1714	C-2714	136-2714
7/8	C-1716	135-1716	C-2716	136-2716

5/16	D-1708	137-1708	D-2708	138-2708
5/16	D-1710	137-1710	D-2710	138-2710
5/16	D-1712	137-1712	D-2712	138-2712
5/16	D-1714	137-1714	D-2714	138-2714
5/16	D-1716	137-1716	D-2716	138-2716



# TUFFALOY STANDARD STRAIGHT TIPS

## KEY TO DESCRIPTION

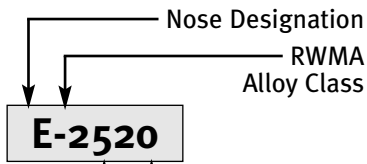

Nose Designation  
RWMA Alloy Class  
**E-2520**  
RW Taper No.  
Length, in Number of 1/4-in. increments  
Example: E nose, class 2, 5RW taper, 5" length  
Contact us if Class 3 (17510) alloy is required

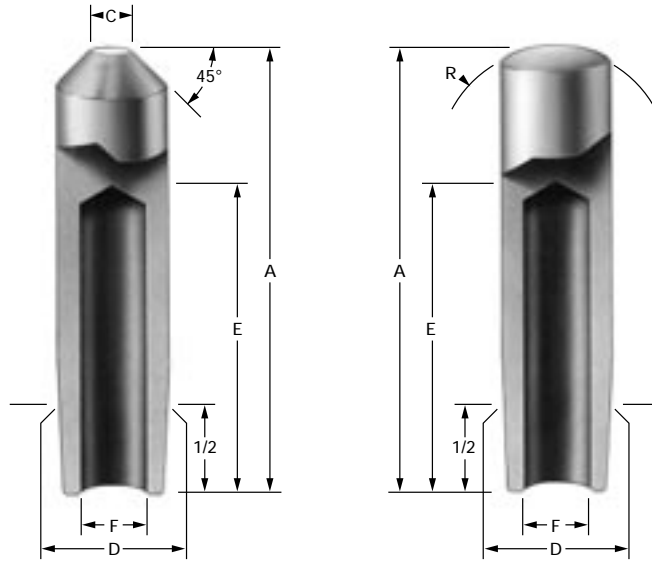

## 'E' TRUNCATED CONE

## 'F' RADIUS FACED

A Overall Length	D Gauging Dia.	E Water Hole Depth	F Water Hole Dia.
------------------------	----------------------	--------------------------	-------------------------

### NO. 4 RW TAPER - 1/2" DIAMETER

1	.463	1/2	9/32
1-1/4	.463	3/4	9/32
1-1/2	.463	1	9/32
1-3/4	.463	1-1/4	9/32
2	.463	1-1/2	9/32
2-1/4	.463	1-3/4	9/32
2-1/2	.463	2	9/32
2-3/4	.463	2-1/4	9/32
3	.463	2-1/2	9/32
3-1/4	.463	2-3/4	9/32
3-1/2	.463	3	9/32
3-3/4	.463	3-1/4	9/32
4	.463	3-1/2	9/32

C Welding Face Dia.	RWMA CLASS 1		RWMA CLASS 2	
	Descrip- tion	Part No.	Descrip- tion	Part No.

3/16	E-1404	140-1404	E-2404	140-2404
3/16	E-1405	140-1405	E-2405	140-2405
3/16	E-1406	140-1406	E-2406	140-2406
3/16	E-1407	140-1407	E-2407	140-2407
3/16	E-1408	140-1408	E-2408	140-2408
3/16	E-1409	140-1409	E-2409	140-2409
3/16	E-1410	140-1410	E-2410	140-2410
3/16	E-1411	140-1411	E-2411	140-2411
3/16	E-1412	140-1412	E-2412	140-2412
3/16	E-1413	140-1413	E-2413	140-2413
3/16	E-1414	140-1414	E-2414	140-2414
3/16	E-1415	140-1415	E-2415	140-2415
3/16	E-1416	140-1416	E-2416	140-2416

R Nose Radius	RWMA CLASS 1		RWMA CLASS 2	
	Descrip- tion	Part No.	Descrip- tion	Part No.

2	F-1404	141-1404	F-2404	141-2404
2	F-1405	141-1405	F-2405	141-2405
2	F-1406	141-1406	F-2406	141-2406
2	F-1407	141-1407	F-2407	141-2407
2	F-1408	141-1408	F-2408	141-2408
2	F-1409	141-1409	F-2409	141-2409
2	F-1410	141-1410	F-2410	141-2410
2	F-1411	141-1411	F-2411	141-2411
2	F-1412	141-1412	F-2412	141-2412
2	F-1413	141-1413	F-2413	141-2413
2	F-1414	141-1414	F-2414	141-2414
2	F-1415	141-1415	F-2415	141-2415
2	F-1416	141-1416	F-2416	141-2416

### NO. 5 RW TAPER - 5/8" DIAMETER

1-1/4	.613	3/4	3/8
1-1/2	.613	3/4	3/8
1-3/4	.613	1	3/8
2	.613	1-1/4	3/8
2-1/4	.613	1-1/2	3/8
2-1/2	.613	1-3/4	3/8
2-3/4	.613	2	3/8
3	.613	2-1/4	3/8
3-1/4	.613	2-1/2	3/8
3-1/2	.613	2-3/4	3/8
3-3/4	.613	3	3/8
4	.613	3-1/4	3/8

1/4	E-1505	140-1505	E-2505	140-2505
1/4	E-1506	140-1506	E-2506	140-2506
1/4	E-1507	140-1507	E-2507	140-2507
1/4	E-1508	140-1508	E-2508	140-2508
1/4	E-1509	140-1509	E-2509	140-2509
1/4	E-1510	140-1510	E-2510	140-2510
1/4	E-1511	140-1511	E-2511	140-2511
1/4	E-1512	140-1512	E-2512	140-2512
1/4	E-1513	140-1513	E-2513	140-2513
1/4	E-1514	140-1514	E-2514	140-2514
1/4	E-1515	140-1515	E-2515	140-2515
1/4	E-1516	140-1516	E-2516	140-2516

2	F-1505	141-1505	F-2505	141-2505
2	F-1506	141-1506	F-2506	141-2506
2	F-1507	141-1507	F-2507	141-2507
2	F-1508	141-1508	F-2508	141-2508
2	F-1509	141-1509	F-2509	141-2509
2	F-1510	141-1510	F-2510	141-2510
2	F-1511	141-1511	F-2511	141-2511
2	F-1512	141-1512	F-2512	141-2512
2	F-1513	141-1513	F-2513	141-2513
2	F-1514	141-1514	F-2514	141-2514
2	F-1515	141-1515	F-2515	141-2515
2	F-1516	141-1516	F-2516	141-2516

### NO. 6 RW TAPER - 3/4" DIAMETER

2	.731	1-1/4	7/16
2-1/2	.731	1-3/4	7/16
3	.731	2-1/4	7/16
3-1/2	.731	2-3/4	7/16
4	.731	3-1/4	7/16

9/32	E-1608	140-1608	E-2608	140-2608
9/32	E-1610	140-1610	E-2610	140-2610
9/32	E-1612	140-1612	E-2612	140-2612
9/32	E-1614	140-1614	E-2614	140-2614
9/32	E-1616	140-1616	E-2616	140-2616

4	F-1608	141-1608	F-2608	141-2608
4	F-1610	141-1610	F-2610	141-2610
4	F-1612	141-1612	F-2612	141-2612
4	F-1614	141-1614	F-2614	141-2614
4	F-1616	141-1616	F-2616	141-2616

### NO. 7 RW TAPER - 7/8" DIAMETER

2	.844	1-1/4	1/2
2-1/2	.844	1-3/4	1/2
3	.844	2-1/4	1/2
3-1/2	.844	2-3/4	1/2
4	.844	3-1/2	1/2

5/16	E-1708	140-1708	E-2708	140-2708
5/16	E-1710	140-1710	E-2710	140-2710
5/16	E-1712	140-1712	E-2712	140-2712
5/16	E-1714	140-1714	E-2714	140-2714
5/16	E-1716	140-1716	E-2716	140-2716

6	F-1708	141-1708	F-2708	141-2708
6	F-1710	141-1710	F-2710	141-2710
6	F-1712	141-1712	F-2712	141-2712
6	F-1714	141-1714	F-2714	141-2714
6	F-1716	141-1716	F-2716	141-2716





TUFFCAP™ electrodes consist of two pieces: a shank and a replaceable cap. These two-part electrodes can offer major economies, because when the nose geometry is worn out, only the cap needs to be replaced. And it costs far less than a standard one-piece electrode. (A TUFFCAP shank will normally outlast twenty caps.) Also, electrode inventory can be kept small because all nose designs will fit the same size shank.

**TWO TYPES:** TUFFALOY offers two kinds of TUFFCAP electrodes. One uses a male cap that fits into the shank. The other has a female cap that fits over the shank.

**FEMALE AND MALE CAPS** are available in the widest range of sizes, alloys, and styles. They are made in both Class 1 (C15000) and Class 2 (C18200) alloys, and in sizes to fit shanks sized 4 through 7 RW. Male caps are more effectively cooled than female caps.

TUFFCAP electrodes are offered with weld faces in conformance with RWMA standards.

**SHANKS** are made of Class 2 (C18200) alloy, either straight, or bent to provide an offset. Shanks other than those cataloged can be special ordered.

TUFFCAP caps and shanks should be used only in a directly opposed, straight-line manner. They do not work as well as standard electrodes on heavily coated metal such as galvanized or tin-plate.

### TUFFTRODE-Z™ CAPS FOR COATED STEELS

To avoid electrode sticking problems common when welding galvanized and aluminized materials, these Class 2 (C18150) copper chrome zirconium alloy caps are offered. They give the same performance as dispersion-strengthened caps but cost far less.

TUFFCAP electrodes are offered with weld faces in conformance with RWMA standards.

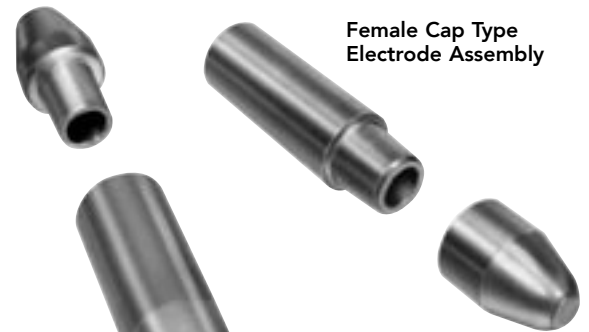

Female Cap Type  
Electrode Assembly



Male Cap Type  
Electrode Assembly

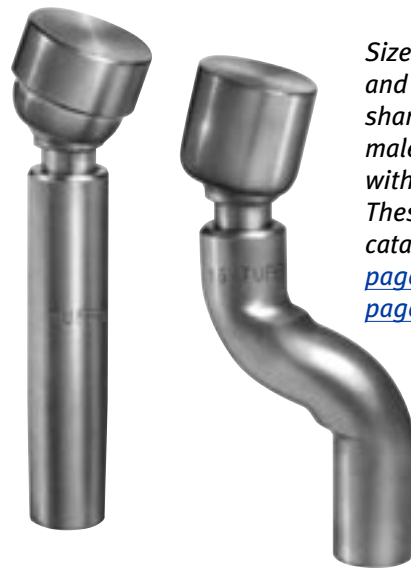

*Size 5 RW straight  
and offset style  
shanks holding  
male type caps  
with swivel heads.  
These caps are  
cataloged on  
[page 8](#) and  
[page 15](#).*

**Note:** For a complete searchable listing of all male and female caps and shanks go to:

[www.tuffaloy.com/products/standard-electrodes/male-caps](http://www.tuffaloy.com/products/standard-electrodes/male-caps)

[www.tuffaloy.com/products/standard-electrodes/straight-shanks-for-male-cap](http://www.tuffaloy.com/products/standard-electrodes/straight-shanks-for-male-cap)

[www.tuffaloy.com/products/standard-electrodes/bent-shanks-for-male-caps](http://www.tuffaloy.com/products/standard-electrodes/bent-shanks-for-male-caps)

[www.tuffaloy.com/products/standard-electrodes/female-caps](http://www.tuffaloy.com/products/standard-electrodes/female-caps)

[www.tuffaloy.com/products/standard-electrodes/straight-shanks-for-female-cap](http://www.tuffaloy.com/products/standard-electrodes/straight-shanks-for-female-cap)

[www.tuffaloy.com/products/standard-electrodes/bent-shanks-for-female-caps](http://www.tuffaloy.com/products/standard-electrodes/bent-shanks-for-female-caps)



# TUFFALOY CAPS AND SHANKS

## STRAIGHT SHANKS FOR MALE CAPS (CLASS 2.18200\*)

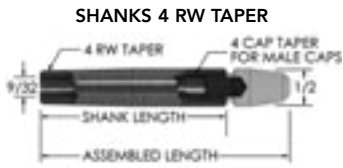

Shank Length	Assembled Length	Description	Part No.
1-1/4	2	TG-2405	161-2405
1-1/2	2-1/4	TG-2406	161-2406
1-3/4	2-1/2	TG-2407	161-2407
2	2-3/4	TG-2408	161-2408
2-1/4	3	TG-2409	161-2409
2-1/2	3-1/4	TG-2410	161-2410
2-3/4	3-1/2	TG-2411	161-2411
3	3-3/4	TG-2412	161-2412
3-1/4	4	TG-2413	161-2413



Shank Length	Assembled Length	Description	Part No.
1-1/4	2	TG-2505	161-2505
1-1/2	2-1/4	TG-2506	161-2506
1-3/4	2-1/2	TG-2507	161-2507
2	2-3/4	TG-2508	161-2508
2-1/4	3	TG-2509	161-2509
2-1/2	3-1/4	TG-2510	161-2510
2-3/4	3-1/2	TG-2511	161-2511
3	3-3/4	TG-2512	161-2512
3-1/4	4	TG-2513	161-2513

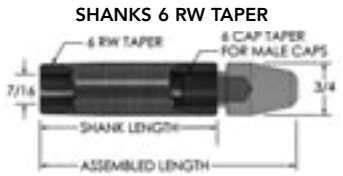

Shank Length	Assembled Length	Description	Part No.
1-1/2	2-1/2	TG-2606	161-2606
2	3	TG-2608	161-2608
2-1/2	3-1/2	TG-2610	161-2610
3	4	TG-2612	161-2612



Shank Length	Assembled Length	Description	Part No.
1-1/2	2-1/2	TG-2706	161-2706
2	3	TG-2708	161-2708
2-1/2	3-1/2	TG-2710	161-2710
3	4	TG-2712	161-2712

**'E' NOSE  
4 AND 5 CAP**



**'F' NOSE  
4 AND 5 CAP**



## BENT SHANKS FOR MALE CAPS (CLASS 2.18200\*)

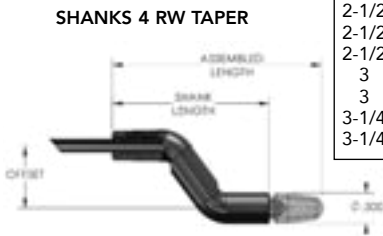

Shank Length	Off-set	Assem. Length	Description	Part No.
2-1/2	1/2	3-1/4	TG-2410-08	162-2410
2-1/2	3/4	3-1/4	TG-2410-12	162-2420
2-1/2	1	3-1/4	TG-2410-16	162-2430
3	1/2	3-3/4	TG-2412-8	162-2450
3	1-1/4	3-3/4	TG-2412-20	162-2460
3-1/4	1	4	TG-2413-16	162-2470
3-1/4	1-1/4	4	TG-2413-20	162-2480

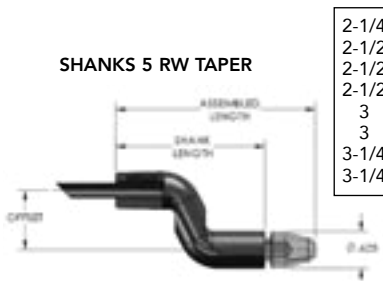

Shank Length	Off-set	Assem. Length	Description	Part No.
2-1/4	1/4	3	TG-2509-4	162-2505
2-1/2	1/2	3-1/4	TG-2510-8	162-2510
2-1/2	3/4	3-1/4	TG-2510-12	162-2520
2-1/2	1	3-1/4	TG-2510-16	162-2530
3	1/2	3-3/4	TG-2512-8	162-2550
3	1-1/4	3-3/4	TG-2512-20	162-2560
3-1/4	1	4	TG-2513-16	162-2570
3-1/4	1-1/4	4	TG-2513-20	162-2580

\* Class 3 Available

## MALE CAPS

### POINTED TIPS 'A'

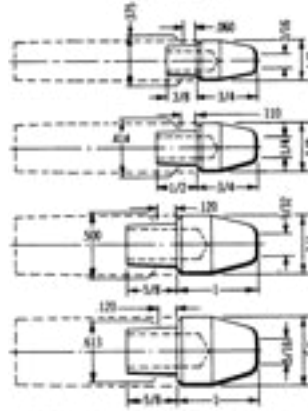

Alloy Class	Cap Taper	Description	Part No.
1	4RW CT	TA-14	111-0014
2	4RW CT	TA-24	112-0024
3	4RW CT	TA-34	122-1034
1	5RW CT	TA-15	111-0015
2	5RW CT	TA-25Z	126-0025
2	5RW CT	TA-25	112-0025
3	5RW CT	TA-35	122-1035
1	6RW CT	TA-16	111-0016
2	6RW CT	TA-26	112-0026
1	7RW CT	TA-17	111-0017
2	7RW CT	TA-27	112-0027

### DOMED TIPS 'B'

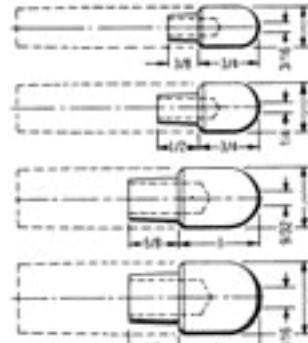

Alloy Class	Cap Taper	Description	Part No.
1	4RW CT	TB-14	113-0014
2	4RW CT	TB-24	114-0024
1	5RW CT	TB-15	113-0015
2	5RW CT	TB-25	114-0025
2	5RW CT	TB-25Z	126-0026
1	6RW CT	TB-16	113-0016
2	6RW CT	TB-26	114-0026
1	7RW CT	TB-17	113-0017
2	7RW CT	TB-27	114-0027

### FLAT TIPS 'C'

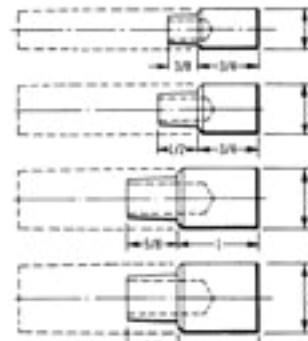

Alloy Class	Cap Taper	Description	Part No.
1	4RW CT	TC-14	115-0014
2	4RW CT	TC-24	116-0024
3	4RW CT	TC-34	122-3034
1	5RW CT	TC-15	115-0015
2	5RW CT	TC-25	116-0025
3	5RW CT	TC-35	122-3035
1	6RW CT	TC-16	115-0016
2	6RW CT	TC-26	116-0026
1	7RW CT	TC-17	115-0017
2	7RW CT	TC-27	116-0027

### OFFSET TIPS 'D'

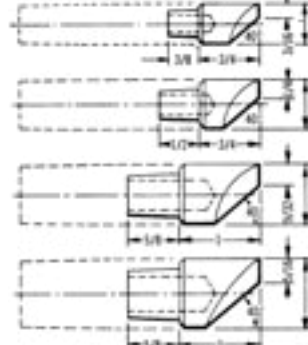

Alloy Class	Cap Taper	Description	Part No.
1	4RW CT	TD-14	117-0014
2	4RW CT	TD-24	118-0024
3	4RW CT	TD-34	122-4034
1	5RW CT	TD-15	117-0015
2	5RW CT	TD-25	118-0025
3	5RW CT	TD-35	122-4035
1	6RW CT	TD-16	117-0016
2	6RW CT	TD-26	118-0026
1	7RW CT	TD-17	117-0017
2	7RW CT	TD-27	118-0027



**STRAIGHT SHANKS FOR FEMALE CAPS (CLASS 2.18200\*)**

**SHANKS 4 RW TAPER**

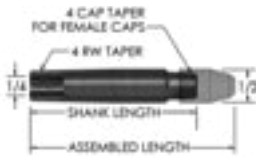

Shank Length	Assembled Length	Description	Part No.
1-1/2	2	TP-2406	163-2406
1-3/4	2-1/4	TP-2407	163-2407
2	2-1/2	TP-2408	163-2408
2-1/4	2-3/4	TP-2409	163-2409
2-1/2	3	TP-2410	163-2410
2-3/4	3-1/4	TP-2411	163-2411
3	3-1/2	TP-2412	163-2412
3-1/4	3-3/4	TP-2413	163-2413
3-1/2	4	TP-2414	163-2414

**SHANKS 5 RW TAPER**



Shank Length	Assembled Length	Description	Part No.
1-1/2	2	TP-2506	163-2506
1-3/4	2-1/4	TP-2507	163-2507
2	2-1/2	TP-2508	163-2508
2-1/4	2-3/4	TP-2509	163-2509
2-1/2	3	TP-2510	163-2510
2-3/4	3-1/4	TP-2511	163-2511
3	3-1/2	TP-2512	163-2512
3-1/4	3-3/4	TP-2513	163-2513
3-1/2	4	TP-2514	163-2514

**SHANKS 6 RW TAPER**

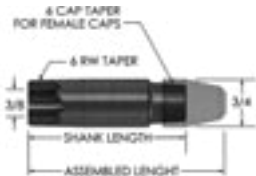

Shank Length	Assembled Length	Description	Part No.
1-1/2	2	TP-2606	163-2606
2	2-1/2	TP-2608	163-2608
2-1/2	3	TP-2610	163-2610
3	3-1/2	TP-2612	163-2612

**'E' NOSE  
4 AND 5 CAP**



**'F' NOSE  
4 AND 5 CAP**



For improved cooling, standard female shanks are drilled through (to put water in contact with cap). Shanks may be ordered with a blind water hole, upon request, add -BH suffix to above part numbers.

**BENT SHANKS FOR FEMALE CAPS (CLASS 2.18200\*)**

**SHANKS 4 RW TAPER**



Shank Length	Off-set	Assem. Length	Description	Item No.
2-3/4	1/2	3-1/4	TP-2411-08	164-2442
2-3/4	3/4	3-1/4	TP-2411-12	164-2445
2-3/4	1	3-1/4	TP-2411-16	164-2447
3-1/4	1/2	3-3/4	TP-2413-08	164-2465
3-1/4	1-1/4	3-3/4	TP-2413-20	164-2480
3-1/2	1	4	TP-2414-16	164-2490

**SHANKS 5 RW TAPER**

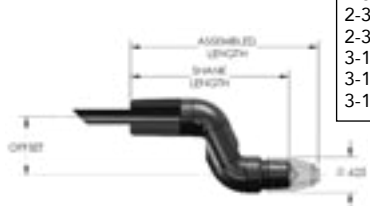

Shank Length	Off-set	Assem. Length	Description	Item No.
2-3/4	1/2	3-1/4	TP-2511-08	164-2542
2-3/4	3/4	3-1/4	TP-2511-12	164-2545
2-3/4	1	3-1/4	TP-2511-16	164-2547
3-1/4	1/2	3-3/4	TP-2513-08	164-2565
3-1/4	1	3-3/4	TP-2513-16	164-2570
3-1/4	1-1/4	3-3/4	TP-2513-20	164-2580

\* Class 3 Available

**FEMALE CAPS**

**POINTED TIPS 'A'**

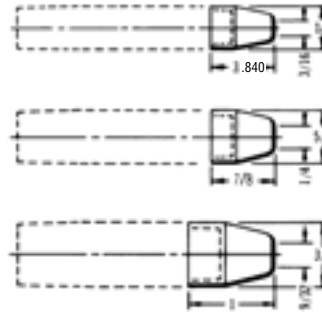

Alloy Class	Cap Taper	Description	Part No.
2 (Cu Cr Zr)	4RW CT	TP-24A	125-0241
2 (Cu Cr Zr)	4RW CT	TP-24AZ	126-0241
2 (Cu Cr Zr)	5RW CT	TP-25A	125-0251
2 (Cu Cr Zr)	5RW CT	TP-25AZ	126-0251
2 (Cu Cr Zr)	6RW CT	TP-26A	125-0261
2 (Cu Cr Zr)	6RW CT	TP-26AZ	126-0261

**DOME TIPS 'B'**

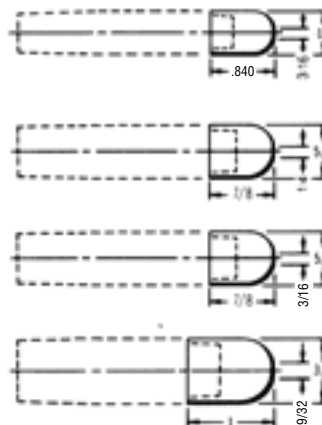

Alloy Class	Cap Taper	Description	Part No.
2 (Cu Cr Zr)	4RW CT	TP-24B	125-0242
2 (Cu Cr Zr)	5RW CT	TP-25B	125-0252
2 (Cu Cr Zr)	5RW CT	TP-25BZ	126-0252
2 (Cu Cr Zr)	5RW CT	TP-25B-.20	125-0252.20
2 (Cu Cr Zr)	5RW CT	TP-25BZ-.20	126-0252.20
2 (Cu Cr Zr)	6RW CT	TP-26B	125-0262
2 (Cu Cr Zr)	6RW CT	TP-26BZ	126-0262

**FLAT TIPS 'C'**

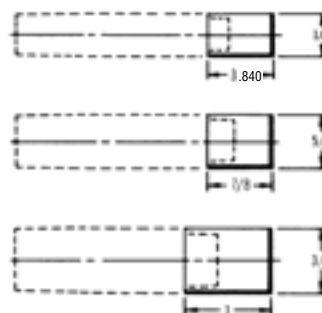

Alloy Class	Cap Taper	Description	Part No.
2 (Cu Cr Zr)	4RW CT	TP-24C	125-0243
2 (Cu Cr Zr)	5RW CT	TP-25C	125-0253
2 (Cu Cr Zr)	5RW CT	TP-25CZ	126-0253
2 (Cu Cr Zr)	6RW CT	TP-26C	125-0263

**OFFSET TIPS 'D'**

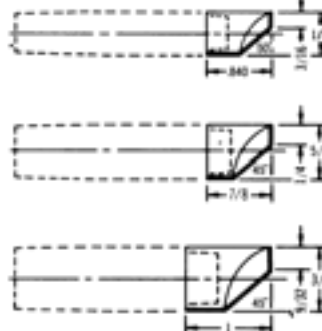

Alloy Class	Cap Taper	Description	Part No.
2 (Cu Cr Zr)	4RW CT	TP-24D	125-0244
2 (Cu Cr Zr)	5RW CT	TP-25D	125-0254
2 (Cu Cr Zr)	5RW CT	TP-25DZ	126-0254
2 (Cu Cr Zr)	6RW CT	TP-26D	125-0264



## DOUBLE BEND ELECTRODE, WITH STANDARD NOSE DESIGNS

These standard cold-formed tips are bent from straight tips (some after added machining) and have the same hardness and conductivity. They outlast, many times over, the old cast and forged tips of similar geometry, which are impossible to cool adequately.

The table shows a wide range of tips generally available from stock. For sizes not shown, refer to the diagrams and description key at the bottom of the page, and order what you need. All measurements will be accurate. However, over-all length, in 1/8-in. multiples, will be held to within 1/16-in.

Tapers, water holes, and nose designs are the same as the standard straight tips in this catalog.

**Water tubes can be furnished, add a -T suffix.**

Standard nose designs other than those shown here may be furnished on short order. Follow the "Key to Description", using a 'B' for Dome nose, 'C' for flat nose, 'E' for truncated cone, and 'F' for radius nose.

## ADDITIONAL NOSE DESIGNS

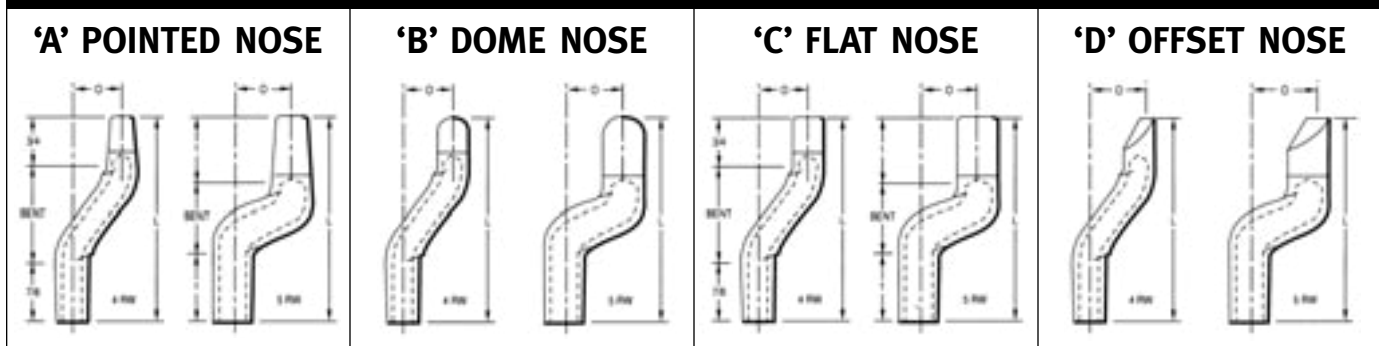

**KEY TO DESCRIPTION**

**FX-YZLD-O**

Example:  
**FB-1438-16-T**

F = Cold-Formed, Double-Bend Tips

X = Nose Type  
A \_\_\_\_\_  
B \_\_\_\_\_  
C \_\_\_\_\_  
D \_\_\_\_\_

Y = RWMA Alloy Class  
1 = Class 1  
2 = Class 2

Z = RW Taper Number  
4 = 4RW  
5 = 5RW

L = Length in inches  
Refer to table for availability

D = Additional Length in 16ths

O = Offset in 16ths  
Refer to table for availability

T = With water tubes

Taper No.	Length	Offset	CLASS 1 (C15000)				CLASS 2 (C18200)			
			FA Pointed Nose		FD Offset Nose		FA Pointed Nose		FD Offset Nose	
			Description	Item No.	Description	Item No.	Description	Item No.	Description	Item No.
3 RW	1-1/2	7/16					FA-2317-8	167-0060		
4 RW	2-3/16	1					FA-2424-8	167-0100	FD-2423-16	167-2080
	2-1/4	1/2	FA-1424-8	165-0100			FA-2424-12	167-0120		
	2-1/4	3/4					FA-2426-6	167-0160		
	2-3/8	3/8	FA-1426-6	165-0160			FA-2426-12	167-0180		
	2-3/8	3/4					FA-2426-20	167-0200	FD-2426-20	167-2200
	2-3/8	1-1/4	FA-1426-20	165-0200	FD-1426-20	165-2200	FA-2428-8	167-0240		
	2-1/2	1/2					FA-2428-16	167-0280	FD-2428-16	167-2280
	2-1/2	1	FA-1428-16	165-0280	FD-1428-16	165-2280	FA-24210-12	167-0320	FD-24210-12	167-2320
	2-5/8	3/4	FA-14210-12	165-0320			FA-24212-8	167-0360	FD-24212-8	167-2360
	2-3/4	1/2	FA-14212-8	165-0360			FA-24212-16	167-0400		
	2-3/4	1					FA-24212-20	167-0420		
	2-3/4	1-1/4					FA-24214-12	167-0430		
2-7/8	3/4					FA-24214-20	167-0460			
2-7/8	1-1/4	FA-14214-20	165-0460			FA-2430-16	167-0520			
3	1	FA-1430-16	165-0520			FA-2436-20	167-0580			
3-3/8	1-1/4					FA-2438-16	167-0620			
3-1/2	1									
5 RW	2-1/4	1/2			FD-1524-20	165-3140			FD-2524-8	167-3100
	2-1/4	1-1/4						FD-2524-20	167-3140	
	2-3/8	3/8	FA-1526-6	165-1160			FA-2526-6	167-1160	FD-2526-6	167-3160
	2-3/8	3/4			FD-1526-12	165-3180	FA-2526-12	167-1180	FD-2526-12	167-3180
	2-1/2	1/2	FA-1528-8	165-1240			FA-2528-8	167-1240		
	2-1/2	1					FA-2528-16	167-1280		
	2-3/4	1/2	FA-15212-8	165-1360	FD-15212-8	165-3360	FA-25212-8	167-1360	FD-25212-8	167-3360
	2-3/4	3/4					FA-25212-12	167-1380		
	2-3/4	1	FA-15212-16	165-1400	FD-15212-16	165-3400	FA-25212-16	167-1400	FD-25212-16	167-3400
	2-7/8	1					FA-25214-16	167-1440		
	2-7/8	1-1/4	FA-15214-20	165-1460			FA-25214-20	167-1460		
	3	1/2	FA-1530-8	165-1480			FA-2530-8	167-1480	FD-2530-8	167-3480
	3	3/4					FA-2530-12	167-1500		
	3	1-3/4					FA-2530-28	167-1540		
	3	1							FD-2530-16	167-3520
3-1/4	1	FA-1534-16	165-1560			FA-2534-16	167-1560			
3-3/8	3/8			FD-1536-6	165-3570					
3-3/8	1-1/4	FA-1536-20	165-1580	FD-1536-20	165-3580	FA-2536-20	167-1580	FD-2536-20	167-3580	
3-1/2	1/2	FA-1538-8	165-1600			FA-2538-8	167-1600			
3-1/2	1					FA-2538-16	167-1620	FD-2538-16	167-3620	



**'A' POINTED NOSE**



FA-1426-6 | FA-2426-6  
FA-1526-6 | FA-2526-6

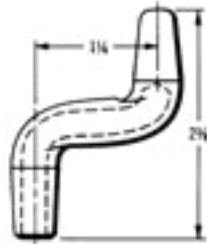

FA-1426-20 | FA-2426-20



FA-1528-8 | FA-2428-8  
FA-1528-8 | FA-2528-8

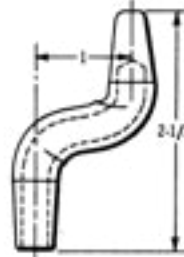

FA-1428-16 | FA-2428-16  
FA-1528-16

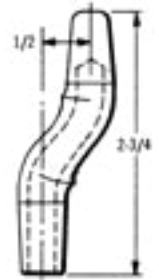

FA-14212-8 | FA-24212-8  
FA-15212-8 | FA-25212-8



FA-15212-16 | FA-25212-16

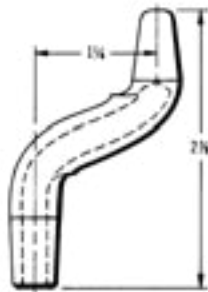

FA-14214-20 | FA-24214-20  
FA-15214-20 | FA-25214-20

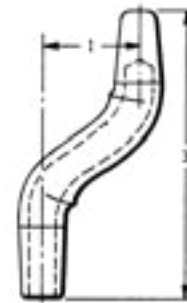

FA-1430-16 | FA-2430-16

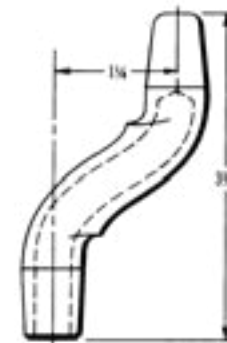

FA-1536-20 | FA-2436-20  
FA-1536-20 | FA-2436-20

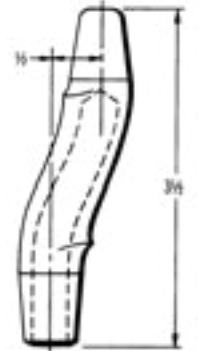

FA-1538-8 | FA-2538-8

**'D' OFFSET NOSE**

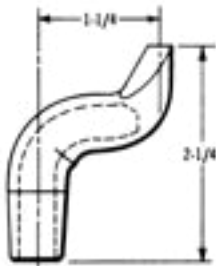

FD-1524-20 | FD-2524-20

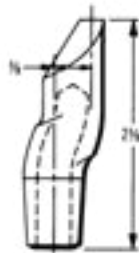

FD-2526-6

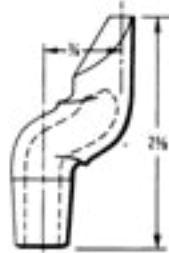

FD-1526-12 | FD-2526-12

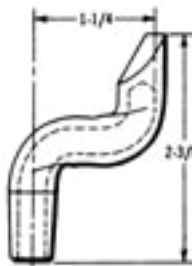

FD-1426-20 | FD-2426-20

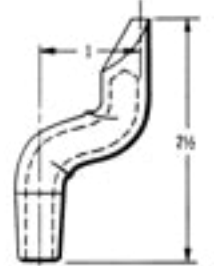

FD-1428-16 | FD-2428-16

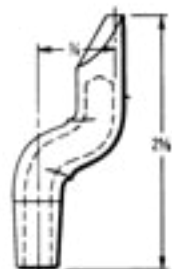

FD-24210-12



FD-15212-8 | FD-24212-8  
FD-15212-8 | FD-25212-8



FD-15212-16 | FD-25212-16

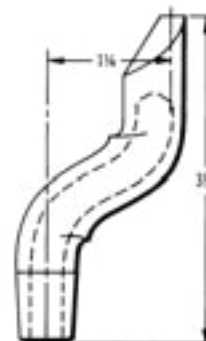

FD-1536-20 | FD-2536-20

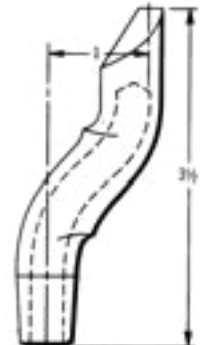

FD-2538-16



**SINGLE-BEND TIPS**

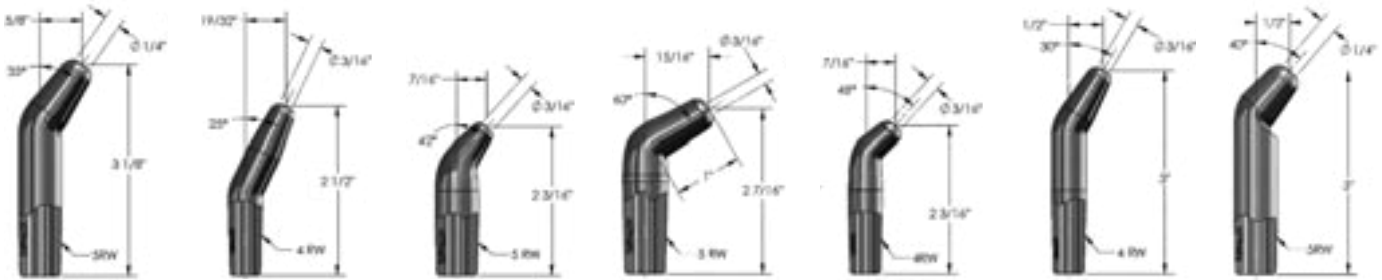

FP-2532-10  
Part No.  
167-5540

FP-2428-9.5  
Part No.  
167-4260

FP-2523-7  
Part No.  
167-5060

FP-2527-15  
Part No.  
167-5220

FP-2423-7  
Part No.  
167-5055

FP-2430-8  
Part No.  
167-5065

FP-2530-8  
Part No.  
167-5070

Cold-formed tips with a single bend have standard pointed-nose design. Other single-bend tips with flat noses (below) or other special designed noses and configurations are available on special order. These are of Class 2 (C18200) alloy. Other alloys can also be ordered.

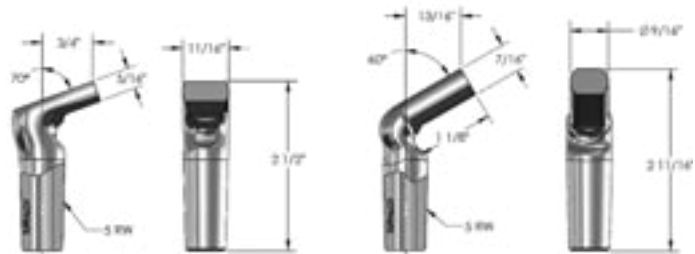

SE-4268  
Part No. 170-4268

SE-4269  
Part No. 170-4269

**MISCELLANEOUS TIPS**

Double bend and flattened tips are made from bar stock. These are some of the standard designs available, but special designs can also be made. These are of Class 2 (C18200) alloy. Other alloys can also be ordered.

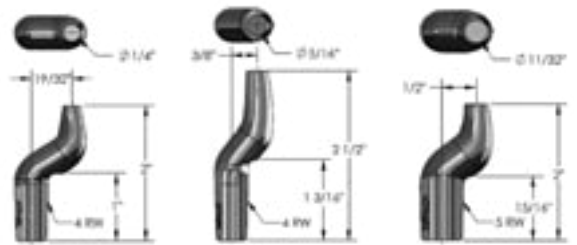

SE-4270  
Part No. 170-4270

SE-4271  
Part No. 170-4271

SE-4272  
Part No. 170-4272



SE-4273  
Part No. 170-4273

SE-4274  
Part No. 170-4274

SE-4275  
Part No. 170-4275

SE-4276-1  
Part No. 170-4276-1

SE-4276  
Part No. 170-4276



These standard bent tips are in addition to those shown on [page 11](#). They are made of Class 2 (C18200) alloy. Other alloys can also be ordered.

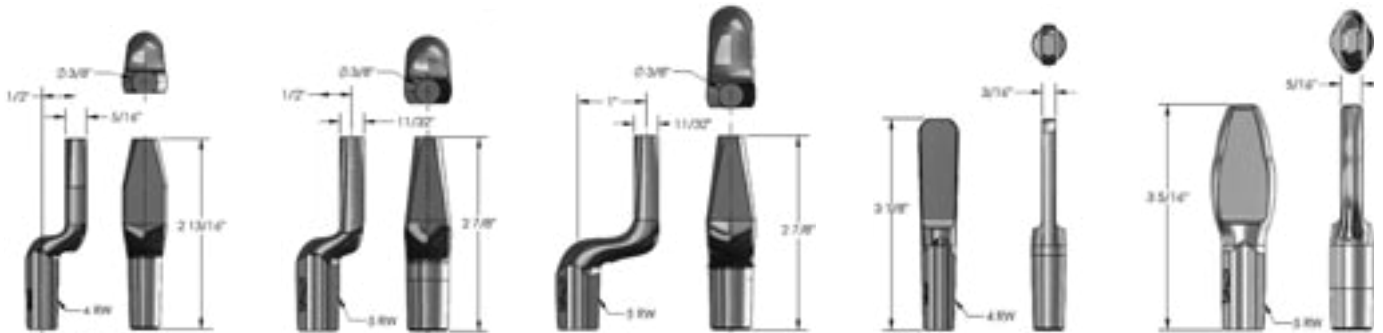

SE-4277  
Part No. 170-4277

SE-4278  
Part No. 170-4278

SE-4279  
Part No. 170-4279

SE-4280  
Part No. 170-4280

SE-4281  
Part No. 170-4281



SE-4282  
Part No. 170-4282

SE-4283  
Part No. 170-4283



SE-4284 (short water hole)  
Part No. 170-4284

SE-4285  
Part No. 170-4285

SE-4286  
Part No. 170-4286



SE-4287  
Part No. 170-4287

SE-4288  
Part No. 170-4288





# TUFFALOY MISCELLANEOUS TIPS

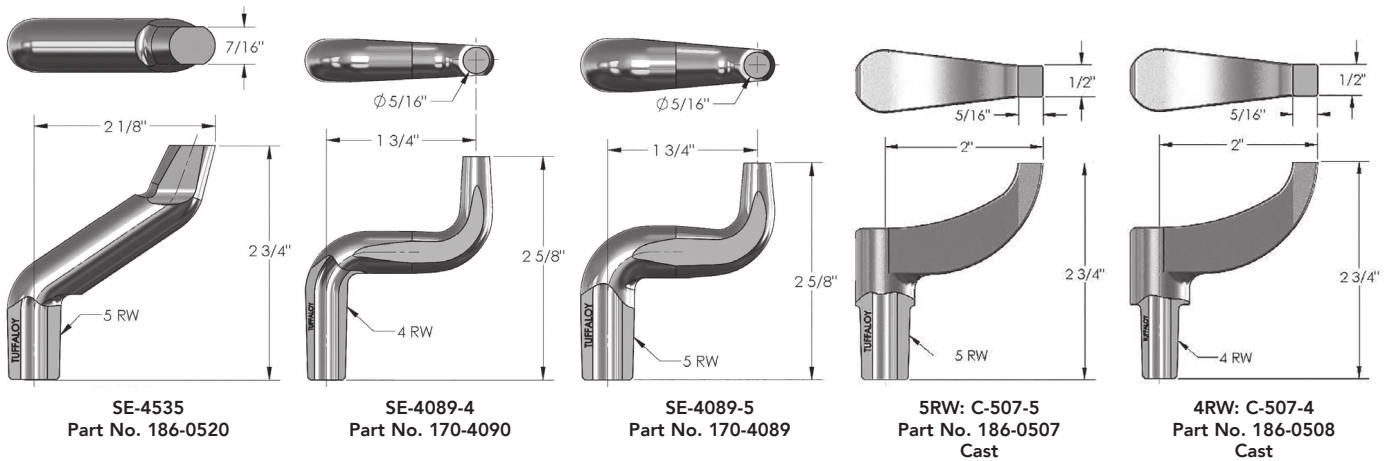

These straight tips have welding faces angled 30°.

Alloy Class	Taper No.	Face 'C'	Length 'D'	Description	Part No.
2	4RW	1/4	2	H-2408-30	145-2408
2	4RW	1/4	3	H-2412-30	145-2412
2	4RW	1/4	4	H-2416-30	145-2416
2	5RW	3/8	2	H-2508-30	145-2508
2	5RW	3/8	3	H-2512-30	145-2512
2	5RW	3/8	4	H-2516-30	145-2516

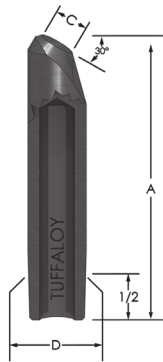

Alloy Class	Taper No.	Length 'N'	Description	Part No.
2	4RW	3/8	N-15	186-0015
2	4RW	3/4	N-16	186-0016
2	5RW	3/8	N-27	186-0027
2	5RW	3/4	N-28	186-0028

N-15 thru N-28

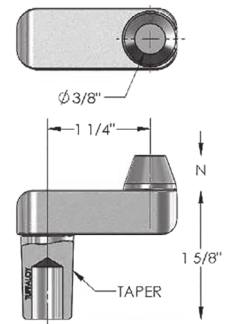

## BACK UP ELECTRODES

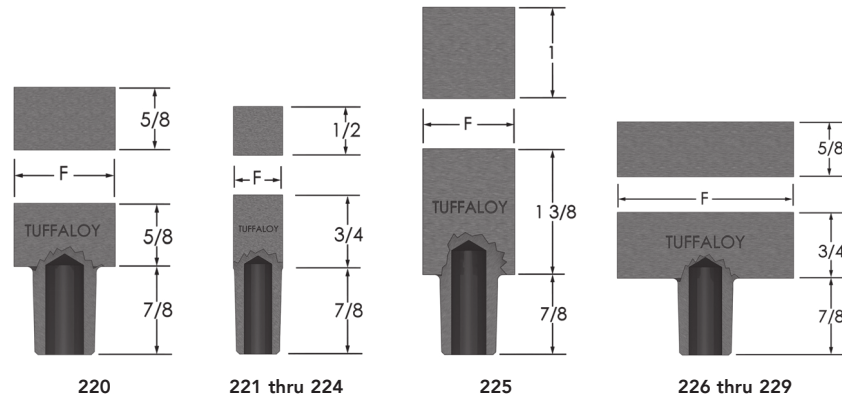

These tips are all machined from bar stock. Special designs can be made to order.

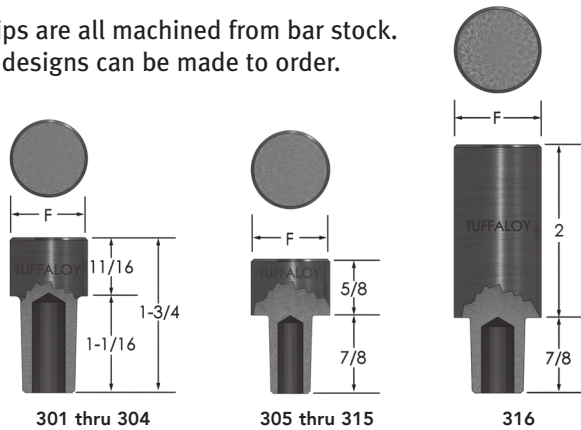

\*311, 313 and 316 available with Copper Tungsten face.

### RECTANGULAR FACE

Alloy Class	Taper No.	Face 'F'	Description	Part No.
2	5RW	1	220	186-0220
2	4RW	1/2	221	186-0221
2	4RW	1	223	186-0223
2	5RW	1	224	186-0224
2	5RW	1	225	186-0225
2	5RW	2	226	186-0226
2	4RW	2	227	186-0227
2	5RW	1-1/2	228	186-0228
2	4RW	1-1/2	229	186-0229

### ROUND FACE

Alloy Class	Taper No.	Face 'F'	Description	Part No.
2	4RW	7/8	301	186-0301
1	4RW	7/8	302	186-0302
2	5RW	7/8	303	186-0303
1	5RW	7/8	304	186-0304
2	4RW	7/8	305	186-0305
1	4RW	7/8	306	186-0306
2	5RW	7/8	307	186-0307
1	5RW	7/8	308	186-0308
2	4RW	1	309	186-0309
1	4RW	1	310	186-0310
2	5RW	1	311*	186-0311
1	5RW	1	312	186-0312
2	5RW	1-1/4	313*	186-0313
2	5RW	1-1/2	315	186-0315
2	5RW	1	316*	186-0316

Additional Back Up Electrodes with Copper Tungsten Facings – See Page 36





Swivel tips have ball-jointed swivel heads to compensate for minor misalignment, and to eliminate marking of the work surface. They are all machined from Class 2 (C18200) bar stock. The S- and SS-Series tip water hole does not reach the head. In the OS and OSH models, the water does contact the head, and O-rings are used to seal it. In the SS Series a spring is used to keep pressure on head for better positioning. **Class 1 (C15000) and Class 3 (C18000) heads are also available.**

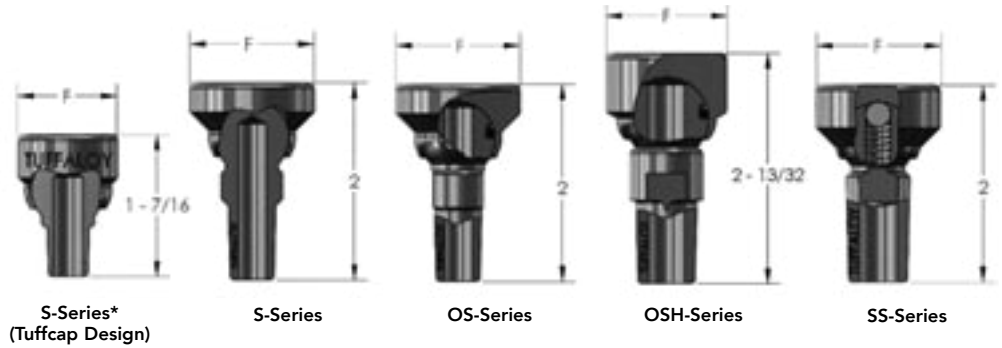

Taper No.	Face Dia. 'F'	S-Series		OS-Series		OSH-Series		SS-Series	
		Description	Part No.	Description	Part No.	Description	Part No.	Description	Part No.
5-CT*	7/8	S-248	182-0248						
	1	S-249	182-0249						
	1-1/4	S-250	182-0250						
4RW	7/8	S-348	182-0348	OS-348	182-1348				
	1	S-350	182-0350	OS-350	182-1350				
	1-1/4	S-351	182-0351	OS-351	182-1351				
5RW	7/8	S-349	182-0349	OS-349	182-1349	OSH-353	182-2353	SS-353	182-3353
	1	S-353	182-0353	OS-353	182-1353	OSH-354	182-2354	SS-354	182-3354
	1-1/4	S-354	182-0354	OS-354	182-1354	OSH-356	182-2356		
	2					OSH-358	182-2358		
7RW	2-1/2					3360	182-3360		

**Note:** Standard swivel tilt is approximately 18°, a 25° swivel is available on request. Add suffix “-HS” to above part number.

\*Will fit Tuffcap adapter shanks having No. 5 RW tapers, as shown on [page 8](#).

**TUFFALOY REFRACTORY METAL-FACED TIPS**

Nose Type	Taper No.	Facing Alloy Class	Dimensions		Description	Part No.
			A	B		
Pointed	4RW	14	3/16	3/8	A-2408-100M	185-0120
	4RW	13	3/16	3/8	A-2408-100W	185-0130
	5RW	11	1/4	3/8	A-2508-10W	185-0150
	5RW	14	1/4	3/8	A-2508-100M	185-0160
	5RW	13	1/4	3/8	A-2508-100W	185-0170
Dome	4RW	11	1/2	1/4	B-2408-10W	185-1110
	5RW	11	5/8	1/4	B-2508-10W	185-1120
	5RW	13	5/8	1/4	B-2508-100W	185-1170
Flat	4RW	11	1/2	1/4	C-2408-10W	185-1210
	4RW	14	1/2	1/4	C-2408-100M	185-1220
	4RW	13	1/2	1/4	C-2408-100W	185-1230
	5RW	11	5/8	1/4	C-2508-10W	185-1250
	5RW	14	5/8	1/4	C-2508-100M	185-1260
5RW	13	5/8	1/4	C-2508-100W	185-1270	

The TUFFALOY copper-tungsten, tungsten and molybdenum-faced tips listed here withstand greater heat and pressure, at the expense of some conductivity. Besides being used for spot welding high resistance base metals, they are useful in achieving “heat balance” when welding dissimilar metals. (The higher resistance electrode is used against the lower resistance, or thinner, member, to help contain the heat generated.) They have the same diameters and tapers as the standard straight tips in this catalog. Bodies are of Class 2 (C18200) alloy. Lengths other than those shown can be ordered.

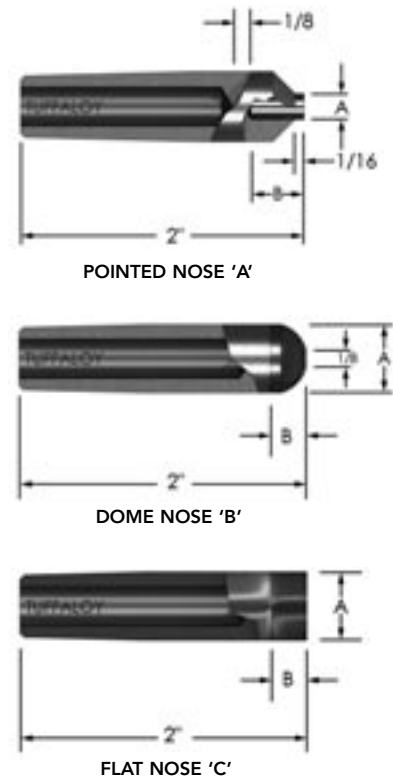

# TUFFALOY THREADED TIPS

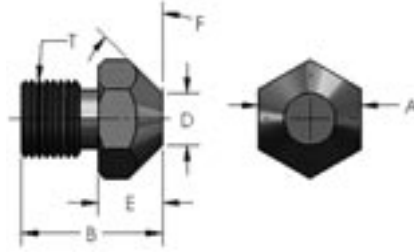

## “A” POINTED NOSE THREADED ELECTRODE

RWMA Alloy Class No.	Part Number	Part Description	T Thread Size	A Hex Size (in)	B Overall Length	D Weld Face Diameter	E Hex Body Length (in)	F Angle
2 (C18200)	188-2431-16-A	TH-2431-16-A	3/8-16	1/2	11/16	1/4	5/16	45°
2 (C18150)	188-2431-16-AZ	TH-2431-16-AZ	3/8-16	1/2	11/16	1/4	5/16	45°
2 (C18150)	188-2437-16-AZ	TH-2437-16-AZ	3/8-16	1/2	3/4	1/4	3/8	45°
2 (C18150)	188-2450-16-AZ	TH-2450-16-AZ	3/8-16	1/2	7/8	1/4	1/2	45°
3 (C18000)	188-3450-16-A	TH-3450-16-A	3/8-16	1/2	7/8	1/4	1/2	45°

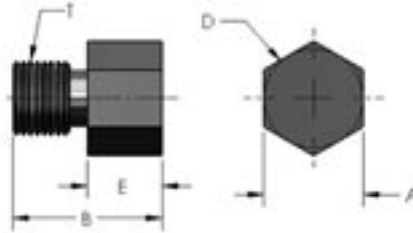

## “C” FLAT NOSE THREADED ELECTRODE

RWMA Alloy Class No.	Part Number	Part Description	T Thread Size	A Hex Size (in)	B Overall Length	D Weld Face Diameter	E Hex Body Length (in)
3 (C18000)	188-3437-16-C	TH-3437-16-C	3/8-16	1/2	3/4	1/2	3/8
2 (C18200)	188-2450-16-C	TH-2450-16-C	3/8-16	1/2	7/8	1/2	1/2
3 (C18000)	188-3450-16-C	TH-3450-16-C	3/8-16	1/2	7/8	1/2	1/2
2 (C18200)	187-5062-14	5062-14-C	7/16-14	5/8	3/4	5/8	3/8
2 (C18200)	187-5062-16	5062-16-C	3/8-16	5/8	3/4	5/8	3/8
2 (C18200)	187-5100-10	5100-10-C	3/4-10	1	2	1	1-3/8
2 (C18200)	187-5125-10	5125-10-C	3/4-10	1-1/4	2	1-1/4	1-3/8
2 (C18200)	187-5100-11	5100-11-C	5/8-11	1	2	1	1-3/8
2 (C18200)	187-5100-18	5100-18-C	5/8-18	1	2	1	1-3/8

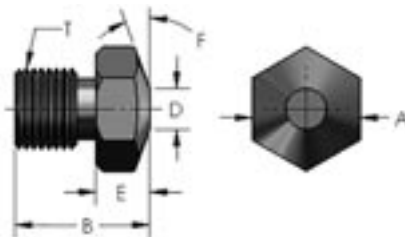

## “E” TRUNCATED NOSE THREADED ELECTRODE

RWMA Alloy Class No.	Part Number	Part Description	T Thread Size	A Hex Size (in)	B Overall Length	D Weld Face Diameter	E Hex Body Length (in)	F Angle
2 (C18200)	188-2425-16-E	TH-2425-16-E	3/8-16	1/2	5/8	3/16	1/4	20°
3 (C18000)	188-3425-16-E	TH-3425-16-E	3/8-16	1/2	5/8	3/16	1/4	20°
3 (C18000)	188-3437-16-E	TH-3437-16-E	3/8-16	1/2	3/4	3/16	3/8	20°
2 (C18200)	188-2450-16-E	TH-2450-16-E	3/8-16	1/2	7/8	3/16	1/2	20°
3 (C18000)	188-3450-16-E	TH-3450-16-E	3/8-16	1/2	7/8	3/16	1/2	20°
2 (C18200)	188-5062-14	5062-14-E	7/16-14	5/8	3/4	1/4	3/8	45°
2 (C18200)	188-5100-11	5100-11-E	5/8-11	1	2	1/2	1-3/8	20°
2 (C18200)	188-5100-18	5100-18-E	5/8-18	1	2	1/2	1-3/8	20°
2 (C18200)	188-5100-10	5100-10-E	3/4-10	1	2	1/2	1-3/8	20°
2 (C18200)	188-5125-10	5125-10-E	3/4-10	1-1/4	2	1/2	1-3/8	20°



TUFFALOY threaded electrode adapters are used to provide longer electrode holder life, by providing a changable tip socket in holders having threaded openings. Class 2 (C18200) alloy. Other alloys available.

A Pipe Thread or Taper	B Taper Socket	C Body Size	D Body Length	E Over-All Length	Description	Part Number
1/2-14 NPT	4RW	1" Hex	1/4	7/8	AD-124-.8	190-1408
			3/8	1	AD-124-1.0	190-1410
			5/8	1-1/4	AD-124-1.2	190-1412
			7/8	1-1/2	AD-124-1.5	190-1415
			1-1/8	1-3/4	AD-124-1.7	190-1417
			1-3/8	2	AD-124-2.0	190-1420
			1-5/8	2-1/4	AD-124-2.2	
			1-7/8	2-1/2	AD-124-2.5	190-1425
			2-1/8	2-3/4	AD-124-2.7	
			2-3/8	3	AD-124-3.0	190-1430
			2-5/8	3-1/4	AD-124-3.2	
			2-7/8	3-1/2	AD-124-3.5	190-1435
			3-1/8	3-3/4	AD-124-3.7	
			3-3/8	4	AD-124-4.0	190-1440
			4-3/8	5	AD-124-5.0	
			1/2-14 NPT	5RW	1" Hex	1/4
3/8	1	AD-125-1.0				190-1510
5/8	1-1/4	AD-125-1.2				190-1512
7/8	1-1/2	AD-125-1.5				190-1515
1	1-5/8	AD-125-1.6				
1-1/8	1-3/4	AD-125-1.7				190-1517
1-3/8	2	AD-125-2.0				190-1520
1-5/8	2-1/4	AD-125-2.2				
1-7/8	2-1/2	AD-125-2.5				190-1525
2-1/8	2-3/4	AD-125-2.7				
2-3/8	3	AD-125-3.0				190-1530
2-5/8	3-1/4	AD-125-3.2				190-1532
2-7/8	3-1/2	AD-125-3.5				190-1535
3-1/8	3-3/4	AD-125-3.7				190-1537
3-3/8	4	AD-125-4.0				190-1540
3-7/8	4-1/2	AD-125-4.5				190-1545
5/8-14 NPT	4RW	1" Hex	1/4	7/8	AD-584-.8	190-2408
			3/8	1	AD-584-1.0	190-2410
			7/8	1-1/2	AD-584-1.5	190-2415
			1-3/8	2	AD-584-2.0	190-2420
5/8-14 NPT	5RW	1" Hex	1/4	7/8	AD-585-.8	190-2508
			3/8	1	AD-585-1.0	190-2510
			5/8	1-1/4	AD-585-1.2	190-2512
			7/8	1-1/2	AD-585-1.5	190-2515
			1-1/8	1-3/4	AD-585-1.7	190-2517
			1-3/8	2	AD-585-2.0	190-2520
			1-7/8	2-1/2	AD-585-2.5	190-2525
			2-3/8	3	AD-585-3.0	190-2530
			3-3/8	4	AD-585-4.0	190-2540
			3/4-14 NPT	5RW	1.25 Hex	3/16
7/16	1-3/8	AD-345-1.3				190-3513
9/16	1-1/2	AD-345-1.5				190-3515
13/16	1-3/4	AD-345-1.7				190-3517
1-1/16	2	AD-345-2.0				190-3520
1-9/16	2-1/2	AD-345-2.5				190-3525
2-1/16	3	AD-345-3.0				190-3530
2-9/16	3-1/2	AD-345-3.5				190-3535
3-1/16	4	AD-345-4.0				190-3540
4-1/16	5	AD-345-5.0				190-3550
3/4-14 NPT	6RW	1.25 Hex	5/16	1-1/4	AD-346-1.2	190-3613
			7/16	1-3/8	AD-346-1.3	190-3615
			9/16	1-1/2	AD-346-1.5	190-3620
			1-1/16	2	AD-346-2.0	190-3625
			1-9/16	2-1/2	AD-346-2.5	190-3627
			1-13/16	2-3/4	AD-346-2.7	190-3630
			2-1/16	3	AD-346-3.0	190-3635
			2-9/16	3-1/2	AD-346-3.5	190-3640
			3-1/16	4	AD-346-4.0	190-3645
			3-9/16	4-1/2	AD-346-4.5	190-3650
3/4-14 NPT	7RW	1.25 Hex	9/16	1-1/2	AD-347-1.5	190-3715
			1-1/16	2	AD-347-2.0	190-3720
			1-9/16	2-1/2	AD-347-2.5	190-3725
			2-1/16	3	AD-347-3.0	190-3730
			2-9/16	3-1/2	AD-347-3.5	190-3735
			3-1/16	4	AD-347-4.0	190-3740
4RW	5RW	1" Hex	1	2	AD-45-2	190-4520
			2	3	AD-45-3	190-4530
			3	4	AD-45-4	190-4540
			5RW	4RW	7/8 Hex	1/4
1	2	AD-54-2				190-5420
1-1/2	2-1/2	AD-54-2.5				190-5425
2	3	AD-54-3				190-5430
3	4	AD-54-4				190-5440
5RW	5RW	7/8 Hex				1
			1-1/2	2-1/2	AD-55-2.5	190-5525
			2	3	AD-55-3	190-5530
			3	4	AD-55-4	190-5540
5RW 6RW 6RW 7RW	6RW 4RW 5RW 4RW	1" Hex 1" Hex 1" Hex 1" Hex	1-1/8	2	AD-56-2	190-5620
			1/4	1-1/4	AD-64-1	190-6410
			1/4	1-1/4	AD-65-1	190-6510
			1/4	1-1/2	AD-74-1	190-7410
7RW	5RW	1" Hex	1/4	1	AD-75-1	190-7510
			3/4	2	AD-75-2	190-7520
			2-1/4	3-1/2	AD-75-3.5	190-7535
			2-3/4	4	AD-75-4	190-7540

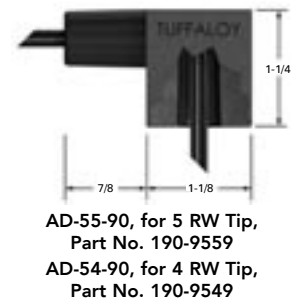
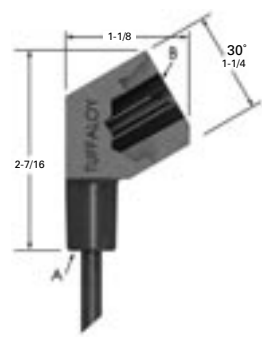
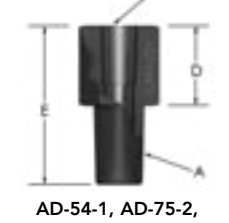
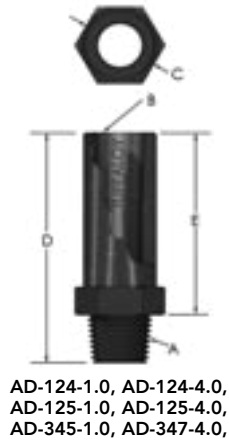
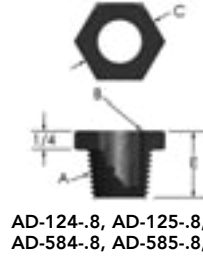

### STRAIGHT THREADED ADAPTERS FOR MULTI-SPOT BARREL AND CLAMP

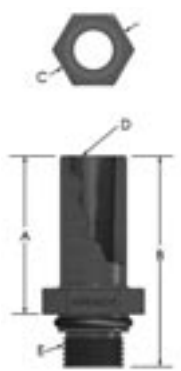

A	B	C	Description	Part No.
<b>D = 4 RW TAPER - E = 7/8-14 NF</b>				
3/8	1-1/8	1.25 Hex	AD-134-1.1	190-3211
1/2	1-1/4		AD-134-1.2	190-3212
5/8	1-3/8		AD-134-1.3	190-3213
3/4	1-1/2		AD-134-1.5	190-3215
1	1-3/4		AD-134-1.7	190-3217
1-1/4	2		AD-134-2.0	190-3220
1-1/2	2-1/4		AD-134-2.2	190-3222
1-3/4	2-1/2		AD-134-2.5	190-3225
2-1/4	3		AD-134-3.0	190-3230
2-3/4	3-1/2		AD-134-3.5	190-3235
<b>D = 5 RW TAPER - E = 7/8-14 NF</b>				
3/8	1-1/8	1.25 Hex	AD-135-1.1	190-3311
1/2	1-1/4		AD-135-1.2	190-3312
5/8	1-3/8		AD-135-1.3	190-3313
3/4	1-1/2		AD-135-1.5	190-3315
1	1-3/4		AD-135-1.7	190-3317
1-1/4	2		AD-135-2.0	190-3320
1-1/2	2-1/4		AD-135-2.2	190-3322
1-3/4	2-1/2		AD-135-2.5	190-3325
2-1/4	3		AD-135-3.0	190-3330
2-3/4	3-1/2		AD-135-3.5	190-3335
<b>D = 5 RW TAPER - E = 1-12 NF</b>				
3/8	1-1/8	1.25 Hex	AD-105-1.1	190-4311
1/2	1-1/4		AD-105-1.2	190-4312
5/8	1-3/8		AD-105-1.3	190-4313
3/4	1-1/2		AD-105-1.5	190-4315
1	1-3/4		AD-105-1.7	190-4317
1-1/4	2		AD-105-2.0	190-4320
1-1/2	2-1/4		AD-105-2.2	190-4322
1-3/4	2-1/2		AD-105-2.5	190-4325
2	2-3/4		AD-105-2.7	190-4327
2-1/4	3		AD-105-3.0	190-4330
2-3/4	3-1/2	AD-105-3.5	190-4335	



# TUFFALOY CYLINDER-MOUNTED HOLDERS

These standard-tip holders are mounted directly to air or hydraulic cylinder pistons. They are ideal for assembling special multi-head resistance welding equipment. Current and coolant water are brought to each of the holders separately.

Electrode adapters for the tip diameter being used and in lengths to suit your set-up are ordered separately: see [page 17](#). Water tubes, for carrying water into the tip, should also be ordered separately. Stationary water tubes are listed below on this page. Water nipples are required and can be found under accessories on [page 47](#).

TUFFALOY offers both straight and offset holders for cylinder mounting. Clamps, hose connections, water tubes and adaptors are not included. Order separately.

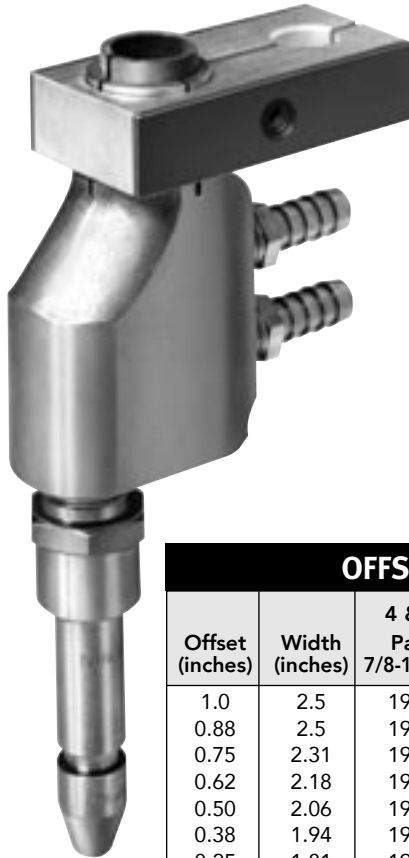

## OFFSET HOLDERS

Offset holders are offered in eight offset sizes, from 1/8 to 1 inch. The standard models have a 1/2-NPT adapter socket, to hold adapters for 4 & 5RW tips. Ordering a 3/4-NPT socket will permit adapters for 6 & 7RW tips to be used. There is also a 7/8-14 threaded adapter socket available. All alloy is Class 2 (C18200).

OFFSET HOLDERS				
Offset (inches)	Width (inches)	4 & 5 RW Part No. 7/8-14 Threads	4 & 5 RW Part No. 1/2" Pipe	6 & 7 RW Part No. 3/4" Pipe
1.0	2.5	194-1578	194-1588	194-1598
0.88	2.5	194-1577	194-1587	
0.75	2.31	194-1576	194-1586	194-1596
0.62	2.18	194-1575	194-1585	
0.50	2.06	194-1574	194-1584	194-1594
0.38	1.94	194-1573	194-1583	
0.25	1.81	194-1572	194-1582	
0.12	1.68	194-1571	194-1581	

## ORDER CLAMP SEPARATELY

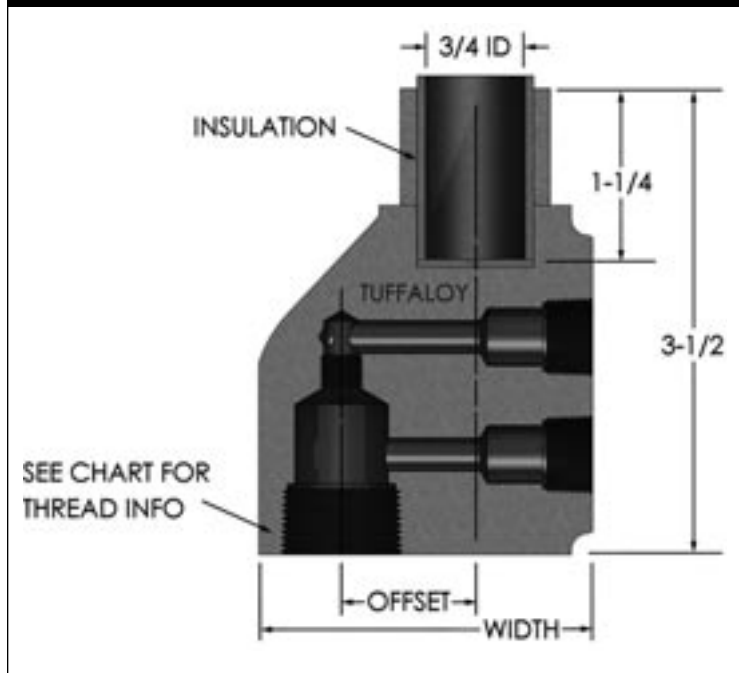

To determine distance adapter sticks out from holder, deduct 1/2-in. from length of adapter selected. Water tubes 1/2-in. longer than adapter will install approximately flush with adapter face.

## STATIONARY WATER TUBES

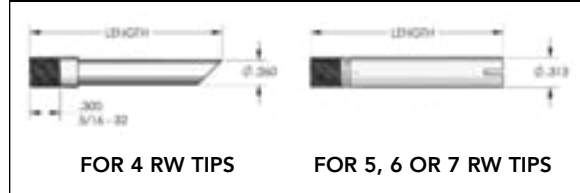

## STATIONARY WATER TUBES

Length	FOR 4RW USE		FOR 5RW, 6RW OR 7RW USE	
	Description	Part No.	Description	Part No.
3/4	301-.7	194-3107	312-.7	194-3207
1	301-1.0	194-3110	312-1.0	194-3210
1-1/4	301-1.2	194-3112	312-1.2	194-3212
1-1/2	301-1.5	194-3115	312-1.5	194-3215
1-3/4	301-1.7	194-3117	312-1.7	194-3217
2	301-2.0	194-3120	312-2.0	194-3220
2-1/2	301-2.5	194-3125	312-2.5	194-3225
3	301-3.0	194-3130	312-3.0	194-3230
3-1/2	301-3.5	194-3135	312-3.5	194-3235
4	301-4.0	194-3140	312-4.0	194-3240
4-1/2	301-4.5	194-3145	312-4.5	194-3245



**STRAIGHT HOLDERS**

Straight holders for multi-spot welding are available in two sizes, to carry tips having four different diameters. Series 101 holders are for 4 & 5RW tips, and Series 102 holders are for 6 & 7RW tips. They may be ordered with one or two sets of coolant ports.

Mating electrical contact surfaces of both the barrels and the clamp are silver plated.

**ADAPTERS FOR MULTI-SPOT BARREL AND CLAMP**

TUFFALOY threaded electrode adapters are used to provide longer electrode holder life, by providing a changeable electrode socket in holders having threaded openings. Standard electrode adapters are made of Class 2 (C18200) alloy. Other alloys available.



**STRAIGHT HOLDERS**

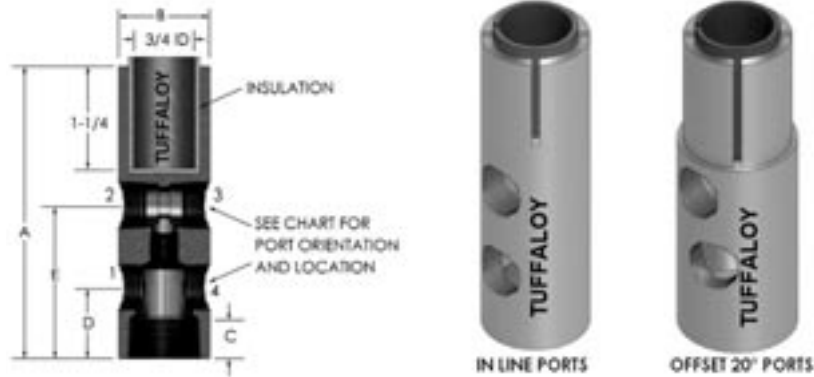

**CYLINDER MOUNTED STRAIGHT BARREL HOLDERS**

Part Number	Description	Overall Length "A" (inches)	Clamping Diameter "B" (inches)	Thread Type	Water In "E"	Water Out "D"	Water Fitting Thread	Water Port Orientation
194-2020	101-A	3.58	1-1/8	1/2-14 NPT	1-7/8	7/8	1/4-18 NPT	In Line 1 & 2
194-2025	101-B	3.58	1-1/8	1/2-14 NPT	1-7/8	7/8	1/4-18 NPT	In Line 1, 2, 3 & 4
194-2026	SH-101-1	3.25	1-1/8	1/2-14 NPT	1-5/8	7/8	1/8-27 NPT	In Line 1, 2, 3 & 4
194-2070	102-A	3.93	1-3/8	3/4-14 NPT	2-3/16	1-3/16	1/4-18 NPT	In Line 1 & 2
194-2075	102-B	3.93	1-3/8	3/4-14 NPT	2-3/16	1-3/16	1/4-18 NPT	In Line 1, 2, 3 & 4
194-2080	103-A	3.58	1-1/8	7/8-14	1-7/8	1-1/16	1/4-18 NPT	In Line 1 & 2
194-2081	SH-101-876	3.58	1-1/8	7/8-14	1-7/8	1-1/16	1/4-18 NPT	In Line 1, 2, 3 & 4
194-2082	653-1036	3.58	1-1/8	7/8-14	1-7/8	1-1/16	1/4-18 NPT	Offset 20° In Line 1 & 2
194-2085	SH-102-B	3.93	1-3/8	1-12	2-3/16	1-3/16	1/4-18 NPT	Offset 20° In Line 1, 2, 3 & 4

**CLAMPS FOR CYLINDER MOUNTED HOLDERS**

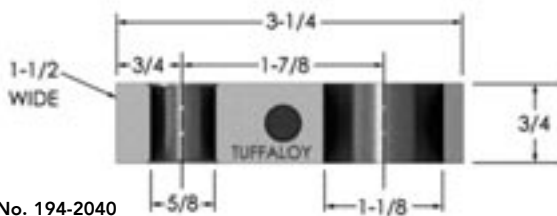

Part No. 194-2040

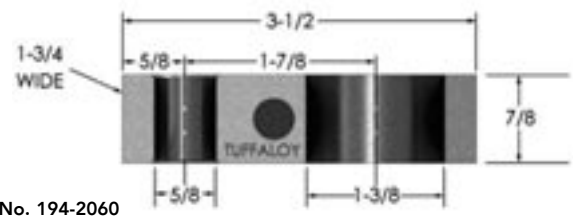

Part No. 194-2060

**CLAMPS FOR CYLINDER MOUNTED HOLDERS**

Part Number	Description	Length (inches)	Width (inches)	Height (inches)	Diameter of Holder Socket (inches)	Diameter of Welding Cable Socket (inches)	Location of Welding Cable Socket (inches)	Location of Holder Socket (inches)
194-2040	101-2	3-1/4	1-1/2	3/4	1-1/8	5/8	3/4	2-5/8
194-2060	102-2	3-1/2	1-3/4	7/8	1-3/8	5/8	5/8	2-1/2



## GOLDCROWN® EJECTOR HOLDERS with self-adjusting water tubes

TUFFALOY Goldcrown® premium ejector holders are made of Class 2 (C18200) alloy and are ground and polished to yield greatest conductivity. These straight tip-ejecting holders deliver dependable, first class performance and are designed with maximum simplicity to require minimum maintenance. All TUFFALOY straight holders feature exclusive spring-loaded self-adjusting water tubes to ensure the proper flow of coolant through resistance welding electrodes. The larger ejector holders incorporate bigger fittings for higher coolant flow rates.

GOLDCROWN				
Barrel Dia.	Tip Socket RW	Barrel Length	Description	Part No.
5/8	4	8	E-05084	320-0100
5/8	4	12	E-05124	320-0120
3/4	4	8	E-06084	320-0140
3/4	5	8	E-06085	320-0150
3/4	4	12	E-06124	320-0160
3/4	5	12	E-06125	320-0170
7/8	4	8	E-07084	320-0180
7/8	5	8	E-07085	320-0190
7/8	4	12	E-07124	320-0200
7/8	5	12	E-07125	320-0210
1	4	8	E-08084	320-0220
1	4	8	E-08084-A	320-0225
1	5	8	E-08085	320-0230
1	5	8	E-08085-A	320-0235
1	6	8	E-08086	320-0240
1	4	12	E-08124	320-0250
1	4	12	E-08124-A	320-0255
1	5	12	E-08125	320-0260
1	5	12	E-08125-A	320-0265
1	6	12	E-08126	320-0270
1-1/4	4	8	E-10084	320-0280
1-1/4	4	8	E-10084-A	320-0285
1-1/4	5	8	E-10085	320-0290
1-1/4	5	8	E-10085-A	320-0295
1-1/4	6	8	E-10086	320-0300
1-1/4	7	8	E-10087	320-0310
1-1/4	4	12	E-10124	320-0320
1-1/4	4	12	E-10124-A	320-0325
1-1/4	5	12	E-10125	320-0330
1-1/4	5	12	E-10125-A	320-0335
1-1/4	6	12	E-10126	320-0340
1-1/4	7	12	E-10127	320-0350
1-1/2	4	8	E-12084	320-0360
1-1/2	4	8	E-12084-A	320-0365
1-1/2	5	8	E-12085	320-0370
1-1/2	5	8	E-12085-A	320-0375
1-1/2	6	8	E-12086	320-0380
1-1/2	6	8	E-12086-A	320-0385
1-1/2	7	8	E-12087	320-0390
1-1/2	4	12	E-12124	320-0410
1-1/2	4	12	E-12124-A	320-0415
1-1/2	5	12	E-12125	320-0420
1-1/2	5	12	E-12125-A	320-0425
1-1/2	6	12	E-12126	320-0440
1-1/2	7	12	E-12127	320-0450

REPLACEMENT ADAPTERS FOR THREADED BARRELS			
Part No.	Description	Taper	THD
195-8550	8550	4RW	5/8-14 NPT
195-8551	8551	5RW	5/8-14 NPT
190-3615	AD-346-1.5	6RW	3/4-14 NPT

These adapters are supplied with -A suffix holder

Suffix “-A” in holder description denotes a threaded tip adapter is supplied

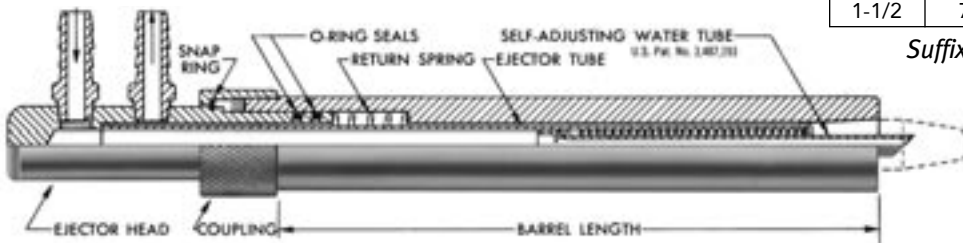

Cross-section of holders with barrels 1 inch or more in diameter.

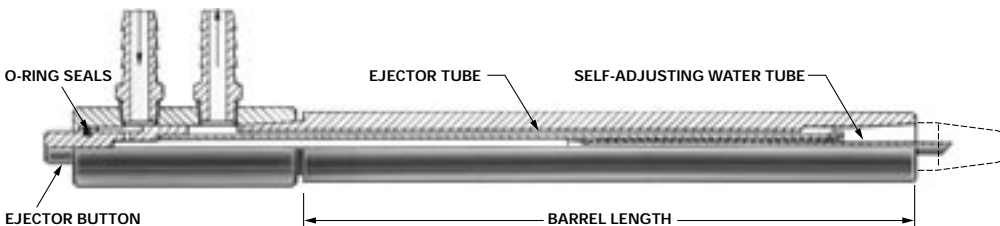

Cross-section of holders with barrels 7/8 inch or less in diameter.



## GOLDSPOT® NON-EJECTOR HOLDERS with self-adjusting water tubes

TUFFALOY Goldcrown® premium non-ejector holders have barrels of Class 2 (C18200) alloy, ground and polished for best conductivity. These straight non-ejector holders are now equipped with the same spring-loaded self-adjusting water tubes as the Goldcrown ejector unit, so electrode cooling is facilitated and improved. They are low in initial cost and inexpensive to maintain. Simple design and few parts contribute to low maintenance cost and excellent performance. Holders are heavy-duty and built to withstand very high welding rates.



*Cross-section view of holders with barrels less than 1 inch diameter.*

REPLACEMENT ADAPTERS FOR THREADED BARRELS			
Part No.	Description	Taper	THD
195-8550	8550	4RW	5/8-14 NPT
195-8551	8551	5RW	5/8-14 NPT
190-3615	AD-346-1.5	6RW	3/4-14 NPT
190-3715	AD-347-1.5	7RW	3/4-14 NPT

*These adapters are supplied with -A suffix holder*

GOLDSPOT				
Barrel Dia.	Tip Socket RW	Barrel Length	Description	Part No.
5/8	4	8	N-05084	325-0100
5/8	4	12	N-05124	325-0120
3/4	4	8	N-06084	325-0140
3/4	5	8	N-06085	325-0150
3/4	4	12	N-06124	325-0160
3/4	5	12	N-06125	325-0170
7/8	4	8	N-07084	325-0180
7/8	5	8	N-07085	325-0190
7/8	4	12	N-07124	325-0200
7/8	5	12	N-07125	325-0210
1	4	8	N-08084	325-0220
1	4	8	N-08084-A	325-0225
1	5	8	N-08085	325-0230
1	5	8	N-08085-A	325-0235
1	6	8	N-08086	325-0240
1	4	12	N-08124	325-0250
1	4	12	N-08124-A	325-0255
1	5	12	N-08125	325-0260
1	5	12	N-08125-A	325-0265
1	6	12	N-08126	325-0270
1-1/4	4	8	N-10084	325-0280
1-1/4	4	8	N-10084-A	325-0285
1-1/4	5	8	N-10085	325-0290
1-1/4	5	8	N-10085-A	325-0295
1-1/4	6	8	N-10086	325-0300
1-1/4	7	8	N-10087	325-0310
1-1/4	7	8	N-10087-A HOLD	325-0315
1-1/4	4	12	N-10124	325-0320
1-1/4	4	12	N-10124-A	325-0325
1-1/4	5	12	N-10125	325-0330
1-1/4	5	12	N-10125-A	325-0335
1-1/4	6	12	N-10126	325-0340
1-1/4	7	12	N-10127	325-0350
1-1/2	4	8	N-12084	325-0360
1-1/2	4	8	N-12084-A	325-0365
1-1/2	5	8	N-12085	325-0370
1-1/2	5	8	N-12085-A	325-0375
1-1/2	6	8	N-12086	325-0380
1-1/2	6	8	N-12086-A HOLD	325-0385
1-1/2	7	8	N-12087	325-0390
1-1/2	4	12	N-12124	325-0410
1-1/2	5	12	N-12125	325-0420
1-1/2	5	12	N-12125-A	325-0425
1-1/2	6	12	N-12126	325-0440
1-1/2	7	12	N-12127	325-0450

*Suffix “-A” in holder description denotes a threaded tip adapter is supplied*

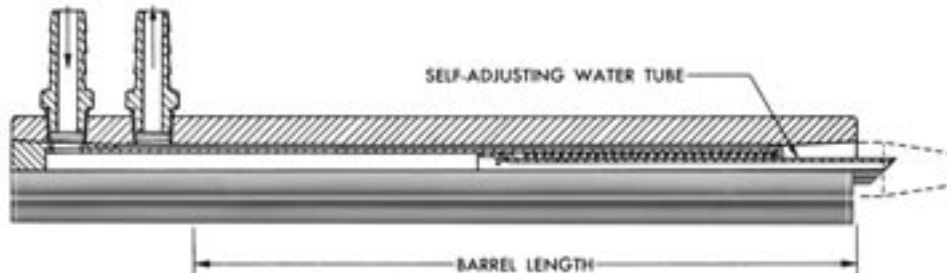

*Cross-section view of holders with barrels 1 inch or more in diameter.*





Part Number	Description	Barrel Length (in)	Barrel Dia. (in)	Tip Socket Taper
319-0206	NHE-08035	3	1	5RW
319-0207	NHE-10035	3	1-1/4	5RW
319-2011	NHE-06084	8	3/4	4RW
319-0212	NHE-07084	8	7/8	4RW
319-0213	NHE-08084	8	1	4RW
319-0214	NHE-10084	8	1-1/4	4RW
319-0216	NHE-08085	8	1	5RW
319-0217	NHE-10085	8	1-1/4	5RW
319-0231	NHE-06124	12	3/4	4RW
319-0232	NHE-07124	12	7/8	4RW
319-0233	NHE-08124	12	1	4RW
319-0234	NHE-10124	12	1-1/4	4RW
319-0236	NHE-08125	12	1	5RW
319-0237	NHE-10125	12	1-1/4	5RW

### TUFFALOY NICKEL PLATED EJECTOR HOLDERS

TUFFALOY nickel plated ejector holders feature high conductivity copper with nickel plated surfaces for corrosion resistance and super conductivity. These holders also feature adjustable water tubes to insure proper water flow for all electrodes.

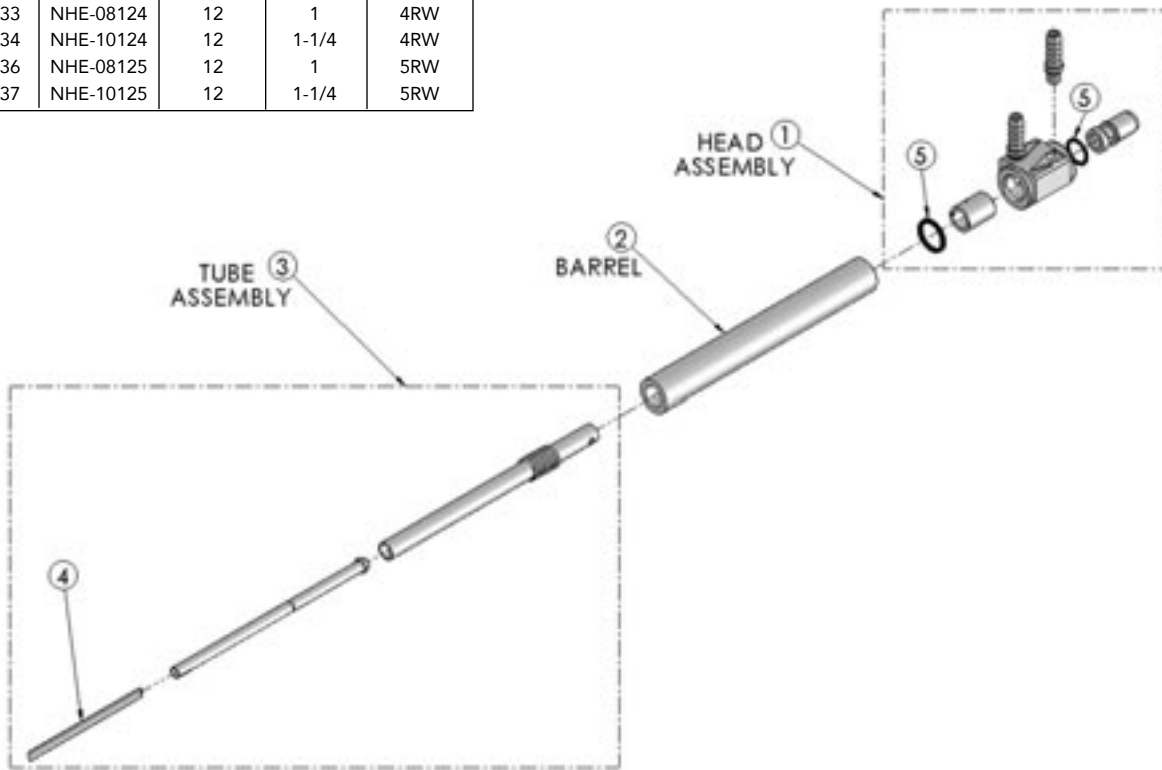

Description	Holder Assy.	1 Head Assy.	2 Barrel	3 Tube Assy.	4 Water Tube	5 Hose O-Ring Kit
NHE-08084	319-0213	195-0101	001-213B	195-0210	195-0017	037-0105
NHE-10084	319-0214	195-0101	001-214B	195-0210	195-0017	037-0105
NHE-08085	319-0216	195-0100	001-216B	195-0208	195-0015	037-0106
NHE-10085	319-0217	195-0100	001-217B	195-0208	195-0015	037-0106
NHE-08124	319-0233	195-0101	001-233B	195-0211	195-0017	037-0105
NHE-10124	319-0234	195-0101	001-234B	195-0211	195-0017	037-0105
NHE-08125	319-0236	195-0100	001-236B	195-0212	195-0015	037-0106
NHE-10125	319-0237	195-0100	001-237B	195-0212	195-0015	037-0106





**CLOSED-COUPLED HOLDERS**

For use where welding space is limited. Standard body length is 3 inches. Other lengths are made on request; minimum length 2 inches.

Body Dia.	Tip Socket	Description	Part No.
3/4	4RW	N-06034	330-0140
7/8	4RW	N-07034	330-0180
7/8	5RW	N-07035	330-0190
1	4RW	N-08034	330-0220
1	5RW	N-08035	330-0230
1-1/4	4RW	N-10034	330-0280
1-1/4	5RW	N-10035	330-0290
1-1/2	4RW	N-12034	330-0360
1-1/2	5RW	N-12035	330-0370

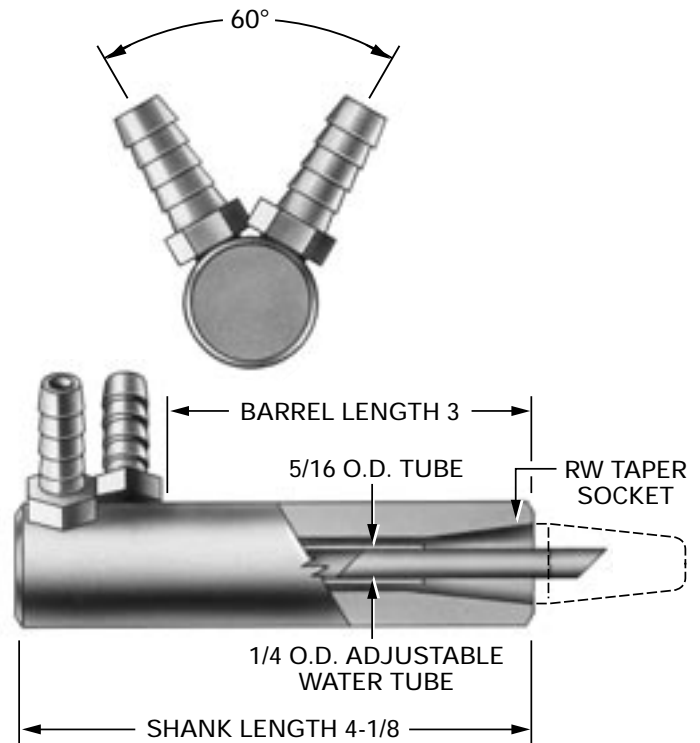

**ADJUSTABLE WATER TUBE USE**

It is very important that resistance welding electrodes be kept as cool as possible; excessive heat softens them, allowing the nose to mushroom and weld quality to drop.

Adjustable water tubes are used to deflect incoming coolant water to the full extent of the water hole in the electrode. Before installing a tip, check that there is an adjustable water tube in place and that it is pulled out far enough so that it will contact the end of the water hole in the tip.

The drawing shows a typical straight holder, but the principle is the same for all types of holders.

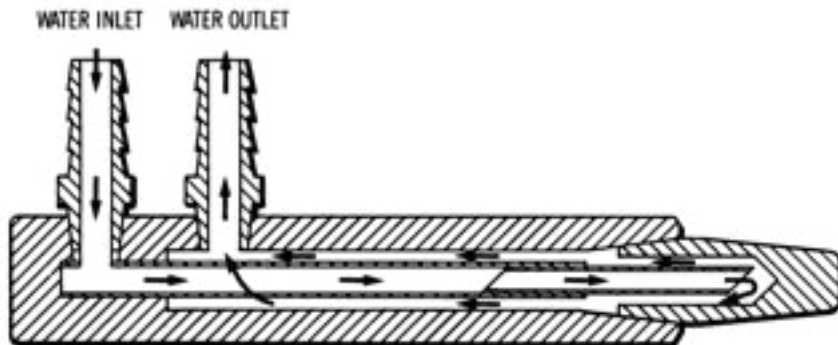

*Adjustable water tube correctly positioned in tip. Cold water will strike the hottest part of the tip first.*



# TUFFALOY OFFSET HOLDERS

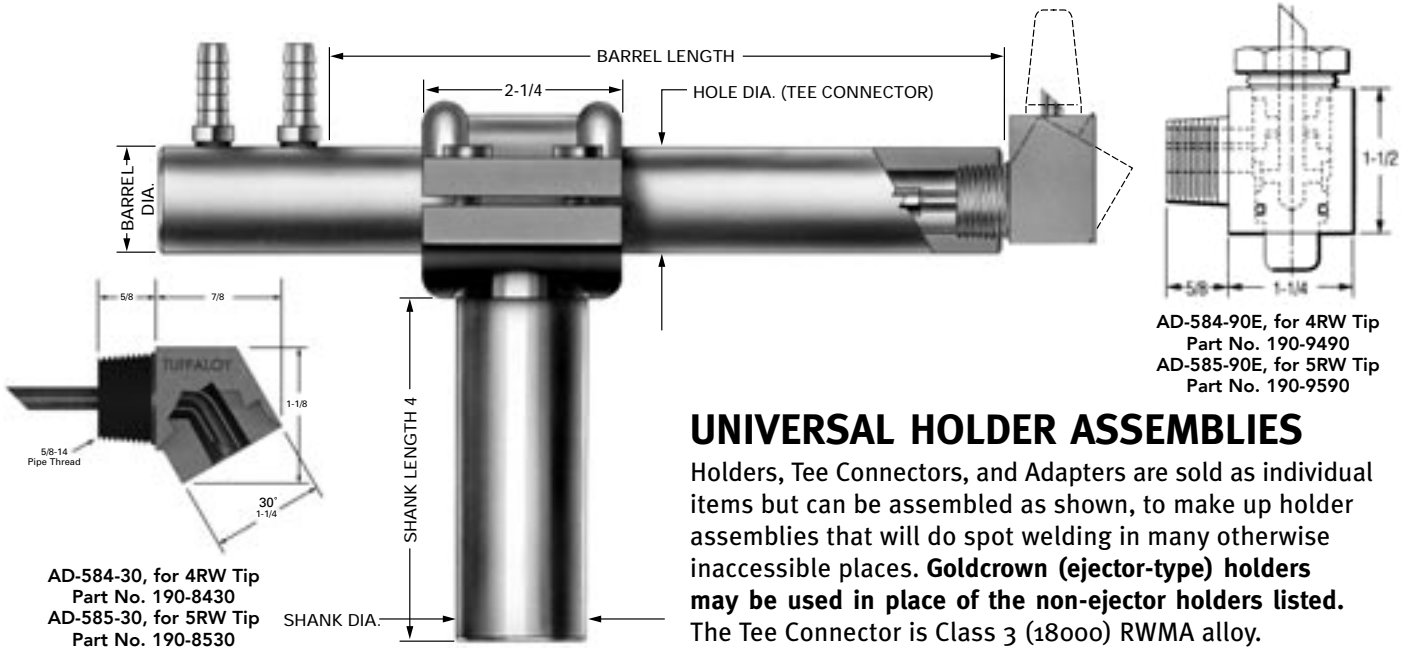

## UNIVERSAL HOLDER ASSEMBLIES

Holders, Tee Connectors, and Adapters are sold as individual items but can be assembled as shown, to make up holder assemblies that will do spot welding in many otherwise inaccessible places. **Goldcrown (ejector-type) holders may be used in place of the non-ejector holders listed.** The Tee Connector is Class 3 (18000) RWMA alloy.

HOLDERS				TEE CONNECTORS			
Barrel Dia.	Barrel Length	Description.	Part No.	Hole Dia.	Shank Dia.	Description	Part No.
1	8	N-08085-A	325-0235	1	1	T-1-1	192-1100
1-1/4	8	N-10085-A	325-0295	1-1/4	1	T-1	192-1000
1-1/4	8	N-10085-A	325-0295	1-1/4	1	T-1	192-1000
1-1/4	8	N-10085-A	325-0295	1-1/4	1-1/4	T-125	192-1250
1-1/4	8	N-10085-A	325-0295	1-1/4	1-1/4	T-125	192-1250
1-1/4	8	N-10085-A	325-0295	1-1/4	1-1/4	T-125	192-1250
1-1/2	8	N-12085-A	325-0375	1-1/2	1-1/2	T-15	192-1500
1-1/2	8	N-12085-A	325-0375	1-1/2	1-1/2	T-15	192-1500
1-1/2	8	N-12085-A	325-0375	1-1/2	1-1/2	T-15	192-1500

ADAPTERS TO CHOOSE FROM			
Tip Socket	Angle Degrees	Description	Part No.
4RW	90	AD-584-90	190-8490
4RW	30	AD-584-30	190-8430
5RW	90	AD-585-90	190-8590
5RW	30	AD-585-30	190-8530
6RW	90	AD-586-90	190-8690

## WELDER ARMS TUFFALOY

Class 2 (C18200) spot welding machine arms made by Tuffaloy reduce set up time and give longer life.

Electrode holder shanks can be attached to these arms from the front, by bolting the cap over them. This means no extra clearance is required between the arms to allow running a shank up (or down) into a hole in the arm. It makes the insertion of Tuffaloy multiple-welding holders much easier.

One of the most common failures of welder arms is the destruction of the bolt hole threads, due to the relatively soft copper involved. Tuffaloy arms have a transverse steel bar insert in which the bolt hole threads are cut. This provides greatly increased thread life.

Standard arm configurations are shown in the table.

Special arm configurations can be ordered upon request.

A Arm Diameter	B Hole Diameter	C Arm Length	Description	Part No.
2	1	12	SH-7320-1	630-7321
		16	SH-7320-2	630-7322
		20	SH-7320-3	630-7323
2-1/2	1-1/4	12	SH-7320-4	630-7324
		16	SH-7320-5	630-7325
		20	SH-7320-6	630-7326
3	1-1/2	12	SH-7320-7	630-7327
		16	SH-7320-8	630-7328
		20	SH-7320-9	630-7329

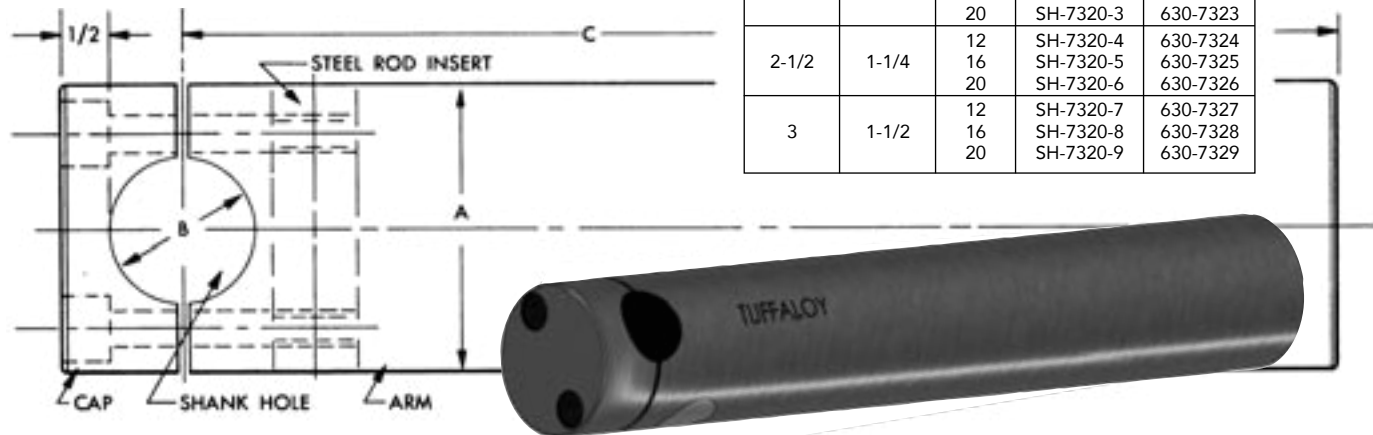

**STANDARD OFFSET HOLDERS**

TUFFALOY Cast Class 2 (C18200) alloy offset holders combine long life with good conductivity. Threaded tip adapters are easily replaced when tip socket is worn beyond use, or when you wish to change to a different taper size.

TUFFALOY offset holders are made in 2- and 4-inch offsets, and in four shank sizes, with 90° and 30° heads. They are supplied with adapters for No. 4 or No. 5 RW taper tips.

Tip Ejector mechanisms are available on all 90° head holders and the 30° head 4-in. offset holders.

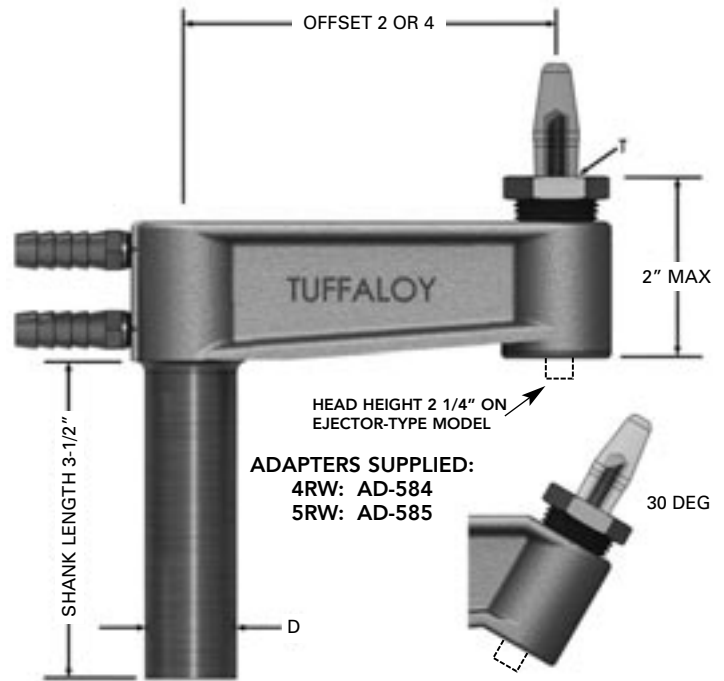

**TWO-INCH OFFSET HOLDERS**

Adapter Tip Socket	Socket Angle	3/4" SHANK DIA.		7/8" SHANK DIA.		1" SHANK DIA.		1-1/4" SHANK DIA.		1-1/2" SHANK DIA.	
		Description	Part No.	Description	Part No.	Description	Part No.	Description	Part No.	Description	Part No.
4RW	30°	ON-754-230	335-1300	ON-874-230	335-1400	ON-14-230	335-1000	ON-1254-230	335-1100	ON-154-230	335-1200
4RW	90°	ON-754-290	335-1310	ON-874-290	335-1410	ON-14-290	335-1010	ON-1254-290	335-1110	ON-154-290	335-1210
5RW	30°	ON-755-230	335-1350	ON-875-230	335-1450	ON-15-230	335-1050	ON-1255-230	335-1150	ON-155-230	335-1250
5RW	90°	ON-755-290	335-1360	ON-875-290	335-1460	ON-15-290	335-1060	ON-1255-290	335-1160	ON-155-290	335-1260

**FOUR-INCH OFFSET HOLDERS**

4RW	30°	ON-754-430	335-1320	ON-874-430	335-1420	ON-14-430	335-1020	ON-1254-430	335-1120	ON-154-430	335-1220
4RW	90°	ON-754-490	335-1330	ON-874-490	335-1430	ON-14-490	335-1030	ON-1254-490	335-1130	ON-154-490	335-1230
5RW	30°	ON-755-430	335-1370	ON-875-430	335-1470	ON-15-430	335-1070	ON-1255-430	335-1170	ON-155-430	335-1270
5RW	90°	ON-755-490	335-1380	ON-875-490	335-1480	ON-15-490	335-1080	ON-1255-490	335-1180	ON-155-490	335-1280

**TWO-INCH EJECTOR STYLE OFFSET HOLDERS**

Adapter Tip Socket	Socket Angle	3/4" SHANK DIA.		7/8" SHANK DIA.		1" SHANK DIA.		1-1/4" SHANK DIA.		1-1/2" SHANK DIA.	
		Description	Part No.	Description	Part No.	Description	Part No.	Description	Part No.	Description	Part No.
4RW	90°	OE-754-290	335-0310	OE-874-290	335-0410	OE-14-290	335-0010	OE-1254-290	335-0110	OE-154-290	335-0210
5RW	90°	OE-755-290	335-0360	OE-875-290	335-0460	OE-15-290	335-0060	OE-1255-290	335-0160	OE-155-290	335-0260

**FOUR-INCH EJECTOR STYLE OFFSET HOLDERS**

4RW	30°	OE-754-430	335-0320	OE-874-430	335-0420	OE-14-430	335-0020	OE-1254-430	335-0120	OE-154-430	335-0220
4RW	90°	OE-754-490	335-0330	OE-874-490	335-0430	OE-14-490	335-0030	OE-1254-490	335-0130	OE-154-490	335-0230
5RW	30°	OE-755-430	335-0370	OE-875-430	335-0470	OE-15-430	335-0070	OE-1255-430	335-0170	OE-155-430	335-0270
5RW	90°	OE-755-490	335-0380	OE-875-490	335-0480	OE-15-490	335-0080	OE-1255-490	335-0180	OE-155-490	335-0280



### VARIABLE OFFSET HOLDERS

Shank Dia.	Description	Part No.
1	SH-7223	345-7223
1-1/4	SH-7224	345-7224
1-1/2	SH-7225	345-7225

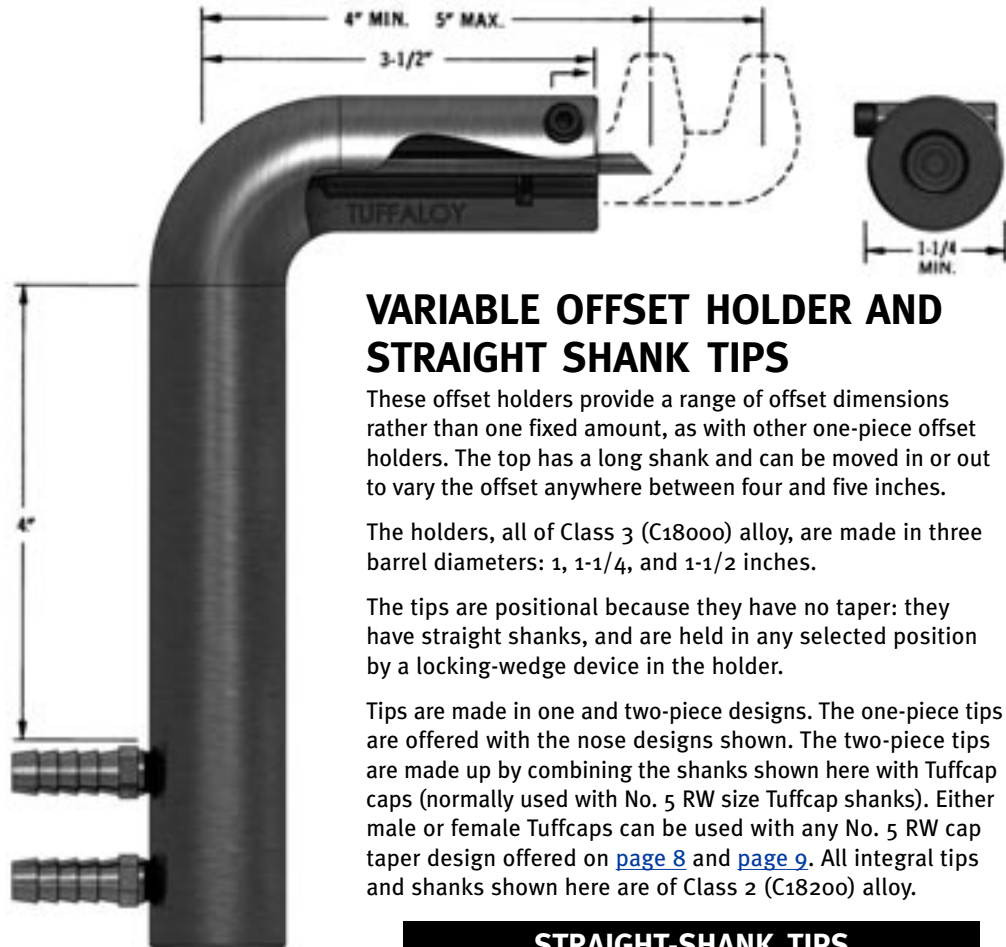
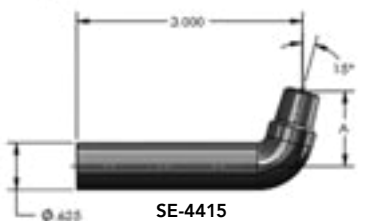
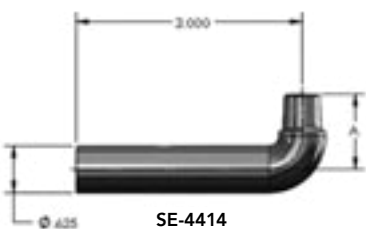
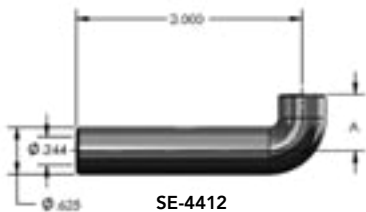
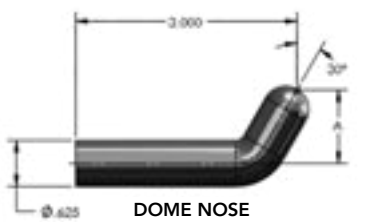
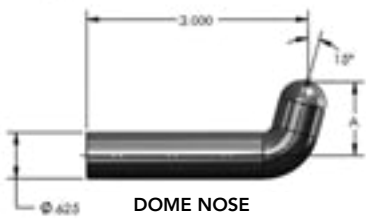
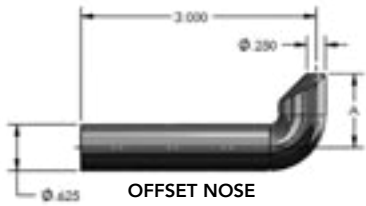
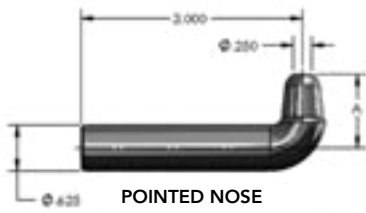

### VARIABLE OFFSET HOLDER AND STRAIGHT SHANK TIPS

These offset holders provide a range of offset dimensions rather than one fixed amount, as with other one-piece offset holders. The top has a long shank and can be moved in or out to vary the offset anywhere between four and five inches.

The holders, all of Class 3 (C18000) alloy, are made in three barrel diameters: 1, 1-1/4, and 1-1/2 inches.

The tips are positional because they have no taper: they have straight shanks, and are held in any selected position by a locking-wedge device in the holder.

Tips are made in one and two-piece designs. The one-piece tips are offered with the nose designs shown. The two-piece tips are made up by combining the shanks shown here with Tuffcap caps (normally used with No. 5 RW size Tuffcap shanks). Either male or female Tuffcaps can be used with any No. 5 RW cap taper design offered on [page 8](#) and [page 9](#). All integral tips and shanks shown here are of Class 2 (C18200) alloy.

### STRAIGHT-SHANK TIPS

Type of Tip	Nose Length 'A'	Description	Part No.
Pointed	1"	SE-4408-1	170-4408
Offset	1"	SE-4409-1	170-4409
15° Dome	1"	SE-4410-1	170-4410
30° Dome	1"	SE-4411-1	170-4411
Pointed	2"	SE-4408-2	170-4418
Offset	2"	SE-4409-2	170-4419
15° Dome	2"	SE-4410-2	170-4420
30° Dome	2"	SE-4411-2	170-4421

### STRAIGHT-SHANK TUFFCAP SHANKS

Tuffcap Cap Type	Nose Length 'A'	Angle	Description	Part No.
Male	3/4"	90°	SE-4412	170-4422
Male	3/4"	15°	SE-4413	170-4423
Female	1"	90°	SE-4414	170-4424
Female	1"	15°	SE-4415	170-4425



## TUFFALOY PADDLE-TYPE HOLDERS AND SOCKET-TYPE TIPS

This holder is for welding in very restricted areas. It provides a very low head height and a four-inch offset. It is made in shank diameters of 3/4, 7/8, 1, and 1-1/4 inches. An adapter bushing is used to add a 1-1/2-in. dia. model to the line. Each holder comes complete with a socket-type tip (SE-3101) and holding screw. The tip may be inserted in either side of the paddle. Holders are of Class 2 (C18200) alloy. Tips are also available in Class 1, Class 2 (18150) and Class 3 alloys.

The four socket-type tips shown here can be used in special welding fixtures and dies as well as in the paddle-type holders.

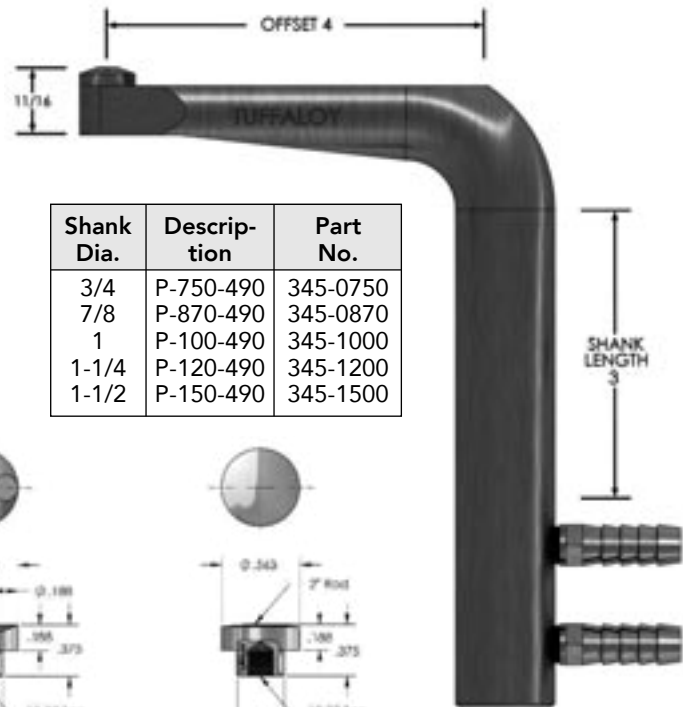

Shank Dia.	Description	Part No.
3/4	P-750-490	345-0750
7/8	P-870-490	345-0870
1	P-100-490	345-1000
1-1/4	P-120-490	345-1200
1-1/2	P-150-490	345-1500

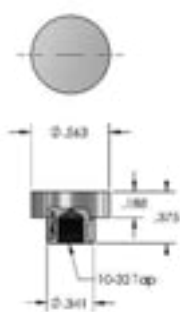

**FLAT FACED**  
Class 1 SE-3099-1  
Part No. 170-3099-1  
Class 2 SE-3099  
Part No. 170-3099  
Class 3 SE-3111  
Part No. 170-3111  
ZIRC SE-3099-Z  
Part No. 170-3099-Z

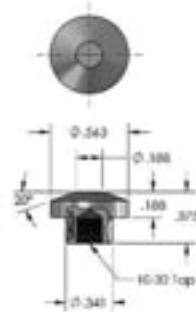

**TRUNCATED CONE**  
Class 1 SE-3101-1  
Part No. 170-3101-1  
Class 2 SE-3101  
Part No. 170-3101  
Class 3 SE-3113  
Part No. 170-3113  
ZIRC SE-3101-Z  
Part No. 170-3101-Z

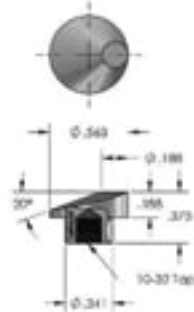

**OFFSET**  
Class 1 SE-3102-1  
Part No. 170-3102-1  
Class 2 SE-3102  
Part No. 170-3102  
Class 3 SE-3123  
Part No. 170-3123  
ZIRC SE-3102-Z  
Part No. 170-3102-Z

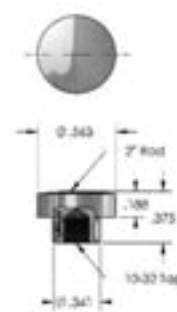

**RADIUS FACED**  
Class 1 SE-3110-1  
Part No. 170-3110-1  
Class 2 SE-3110  
Part No. 170-3110  
Class 3 SE-3133  
Part No. 170-3133  
ZIRC SE-3110-Z  
Part No. 170-3110-Z

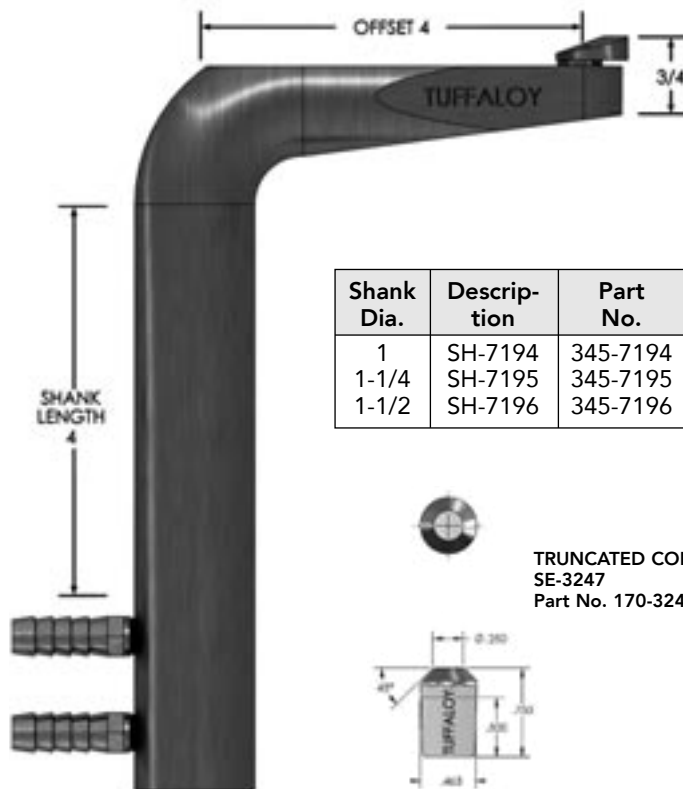

Shank Dia.	Description	Part No.
1	SH-7194	345-7194
1-1/4	SH-7195	345-7195
1-1/2	SH-7196	345-7196

## TUFFALOY HEAVY-DUTY PADDLE-TYPE HOLDERS AND TIPS

TUFFALOY heavy-duty paddle-type holders are made of the stronger Class 3 (C18000) alloy, for greater rigidity and minimum deflection, even under loads of 1000 pounds and more. Class 3 (C18000) alloy provides 154% more tensile strength. Head height is a low 3/4-in. and the shank length is a usable 4 inches.

Three low-profile electrodes of Class 2 (C18200) alloy are offered for use in this heavy-duty holder. If applications permit greater head height, any standard No. 4 RW tip may be used.

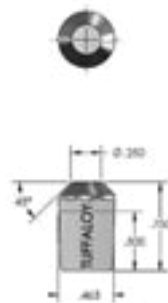

**TRUNCATED CONE**  
SE-3247  
Part No. 170-3247

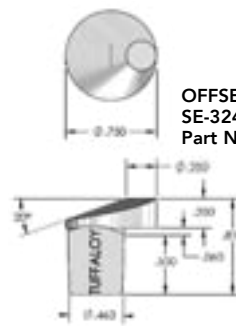

**OFFSET**  
SE-3248  
Part No. 170-3248

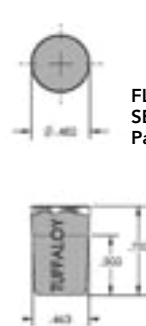

**FLAT FACED**  
SE-3249  
Part No. 170-3249



## HIGH PRESSURE TIPS

Spot and projection welding operations may utilize pressures over 2000 lbs. TUFFALOY high-pressure tips have flat bottoms which eliminates tip jamming in tapered holders. Assembled tip and holder heights are always the same, as contrasted to tapered tips which can be forced into the sockets varying distances.

TUFFALOY high pressure tips can be used in the two holder styles shown: PM holders for mounting on the platens of press-type welders, and straight holders for spot welder arm mounting. The tips are held to the holders by a threaded coupling. Copper tungsten faced tips are available for high pressure wear and projection welding.

### FLAT FACED

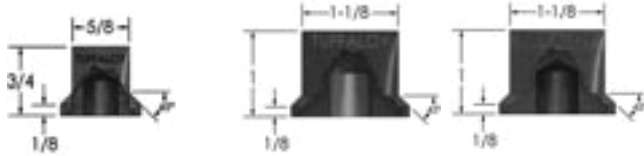

Size 1 PMC-2503  
Part No. 180-2203  
Part No. 180-2203-10W

Size 2 PMC-2104  
Part No. 180-1040  
Part No. 180-2104-10W

### TRUNCATED CONE

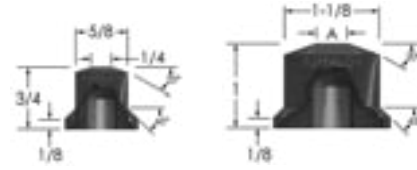

Size 1 PME-2503  
Part No. 180-2303

#### Size 2

'A'	Description	Part No.
1/4	PME-21041	180-1041
5/16	PME-21042	180-1042
3/8	PME-21043	180-1043
7/16	PME-21044	180-1044
1/2	PME-21045	180-1045

### DOME NOSED

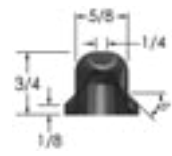

Size 1 PMB-2503  
Part No. 180-2103

## STRAIGHT HOLDERS CLASS 2 ALLOY

Straight holders are made for carrying TUFFALOY high pressure tips in rocker arm welders or press-type welder horn extensions. They are made in two basic sizes, to accommodate Size 1 and Size 2 High Pressure tips. They are of Class 2 (C18200) alloy and hold the tips in the same manner as do the PM holders.

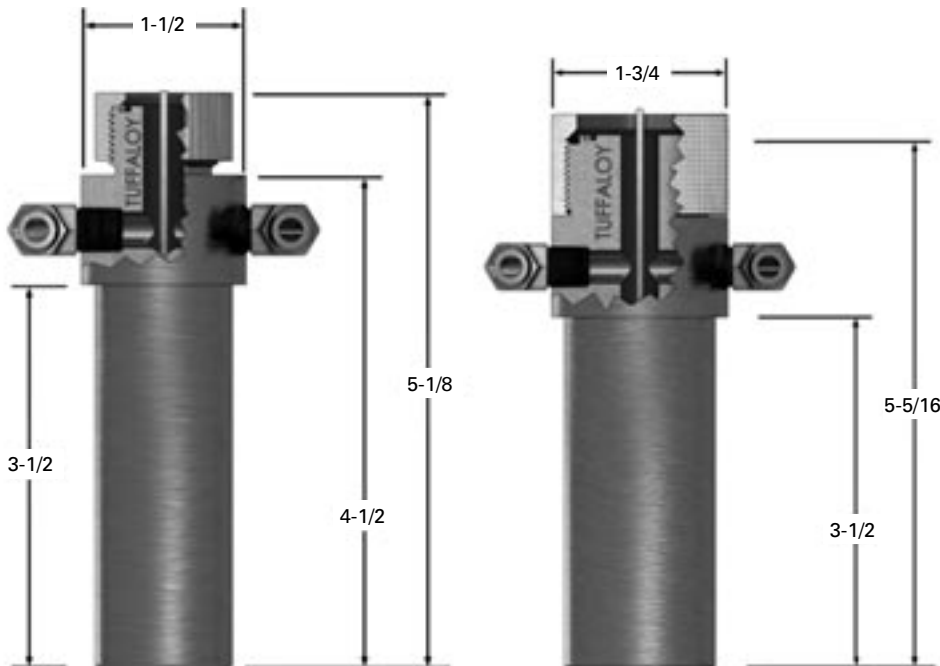

Size	Barrel Dia.	Description	Part No.
1	1	4511	350-4511
1	1-1/4	4512	350-4512
1	1-1/2	4513	350-4513
2	1-1/4	4521	350-4521
2	1-1/2	4522	350-4522



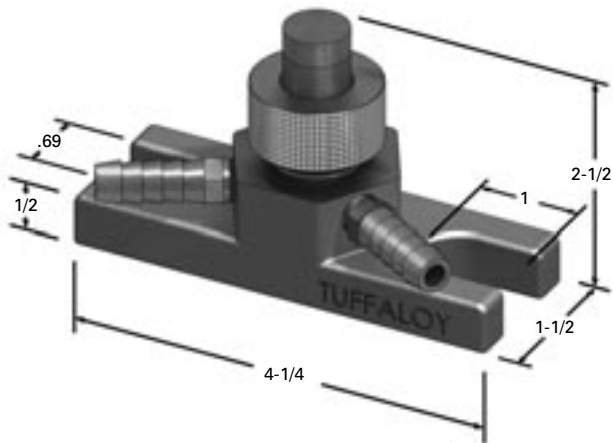

Size 1 PM holder (9/16-in. mounting bolts)  
4510 holder, Part No. 350-4510

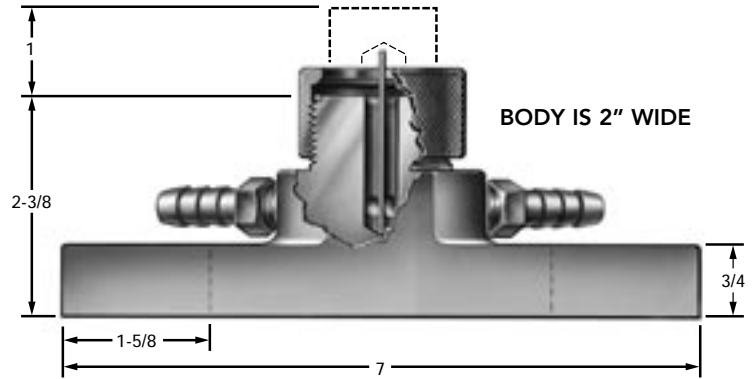

Size 2 PM holder (3/4-in. mounting bolts)  
4520 holder, Part No. 350-4520

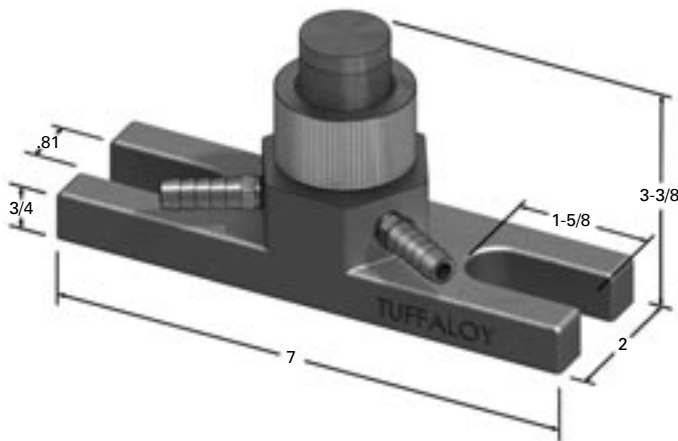

**PM HOLDERS**

TUFFALOY PM holders may be mounted directly to press-type welder platens, or they can be used as components of special weld fixturing. They come in two sizes, which match standard T-slot spacings (either of which can be furnished to hold any of the four standard tips: 4, 5, 6 or 7 RW). The smaller holder is for use on RWMA Size 1 welders, which have the 3-1/2" spacing. The larger one is for the Size 2 and 3 welders, which have the 5- and 6-inch spacing.

Big, half-inch mounting bolts may be used to assure good conductivity. The holders may be used one-to-one or in multiples closely bunched. PM holders make special fixture building easy. They can be bolted to a fixture or back-up base as easily as to a platen. They are compact and have self-contained coolant systems. These PM holders are made of Class 2 (C18200) alloy.

**Fixture Building:** PM holders make special fixture building easy too. They can be bolted to a fixture or backup base as easily as to a platen. They are compact and have self-contained coolant systems that eliminate making a coolant manifold out of the fixture.

**Hose Connections:** You may specify where you want the hose connectors in the hexagonal base. Select any two of the six possible locations and specify by using the symbols shown on the diagram (connector locations: A-B, or A-D, etc.). Position A-C is standard. (A-F and C-D are not possible.)

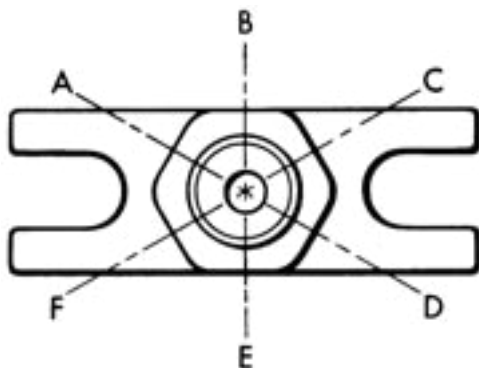

Hose Connection Orientation Options



# TUFFALOY PLATEN-MOUNTED HOLDERS

## PM HOLDERS

TUFFALOY PM holders may be mounted directly to press-type welder platens, or they can be used as components of special weld fixturing. They come in two sizes, which match standard T-slot spacings (either of which can be furnished to hold any of the four standard tips: 4, 5, 6 or 7 RW). The smaller holder is for use on RWMA Size 1 welders, which have the 3-1/2" spacing. The larger one is for the Size 2 and 3 welders, which have the 5- and 6-inch spacing.

Big, half-inch mounting bolts may be used to assure good conductivity. The holders may be used one-to-one or in multiples closely bunched. PM holders make special fixture building easy. They can be bolted to a fixture or back-up base as easily as to a platen. They are compact and have self-contained coolant systems. These PM holders are made of Class 2 (C18200) alloy.

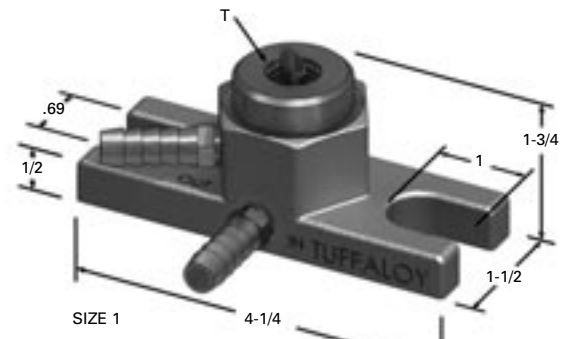

Size 1 PM Holder (5/8" mounting bolts)

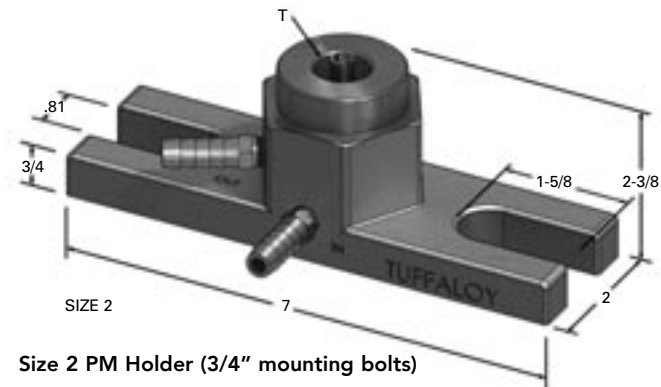

Size 2 PM Holder (3/4" mounting bolts)

STANDARD TIP PM HOLDERS				
RW Tip Socket	Size 1 (Small)		Size 2 (Large)	
	Description	Part No.	Description	Part No.
4	4560	350-4560	4570	350-4570
5	4561	350-4561	4571	350-4571
6	4562	350-4562	4572	350-4572
7	4563	350-4563	4573	350-4573

FOR THREADED ELECTRODES		
Thread Size	Size 1	Size 2
5/8-11	350-4580	350-4590
3/4-10	350-4581	350-4591

FOR THREADED ADAPTERS		
Thread Size	Size 1	Size 2
7/8-14	350-4582	350-4592
1-12	350-4583	350-4593

See adapters [page 17](#)

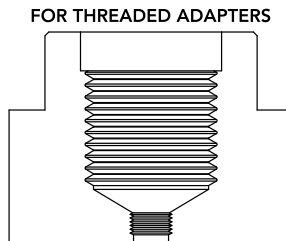
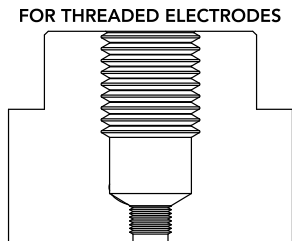

NUT AND STUD PM HOLDERS					
PM Holders T-Slot Spacing	Holder Size	For 1" Dia. Electrodes		For 1-1/2" Dia. Electrodes	
		Description	Part No.	Description	Part No.
3-1/2	1PM	4515	350-4515	4526	350-4526
5 & 6	2PM	4525	350-4525		

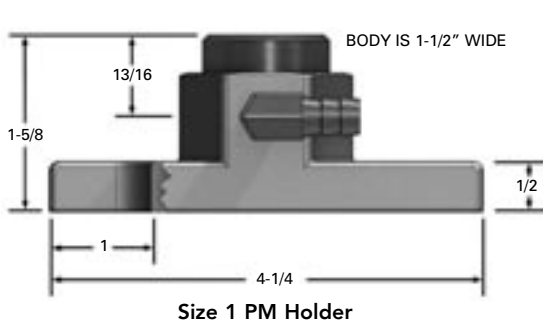

Size 1 PM Holder

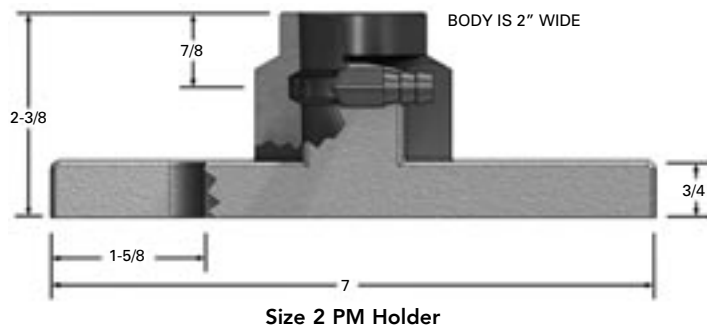

Size 2 PM Holder





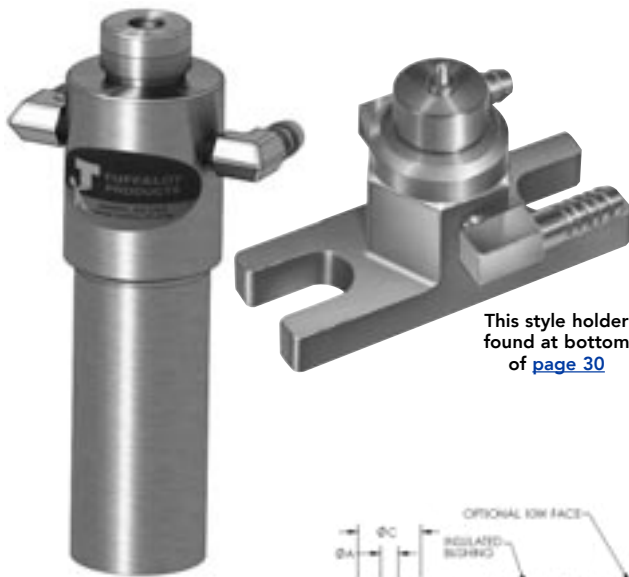

This style holder found at bottom of [page 30](#)

This style holder found at top of [page 32](#)

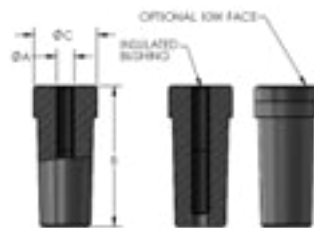

The various types and sizes of TUFFALOY stud-and-nut welding electrodes and holders are described below. For excessive wear applications, any of these electrodes can be ordered with refractory alloy facings, such as TUFFALOY 10W.

**STUD ELECTRODES**

A	B	C	Description	Part No.	With 10W Face Refractory - Item Number
#06 (.150)	2-1/4	1	400	175-4001	175-4001-10W
#08 (.164)			401	175-4011	175-4011-10W
#10 (.190)			402	175-4021	175-4021-10W
#12 (.216)			403	175-4031	175-4031-10W
1/4			404	175-4041	175-4041-10W
5/16 & 8mm			405	175-4051	175-4051-10W
3/8			406	175-4061	175-4061-10W
6mm			506	175-5061	175-5061-10W
7mm			507	175-5071	175-5071-10W
9mm			509	175-5091	175-5091-10W
10mm			510	175-5101	175-5101-10W
3/8	2-3/4	1-1/2	436	175-4361	175-4361-10W
7/16			437	175-4371	175-4371-10W
1/2			438	175-4381	175-4381-10W
9/16			439	175-4391	175-4391-10W
5/8			440	175-4401	175-4401-10W
11/16			441	175-4411	175-4411-10W
3/4			442	175-4421	175-4421-10W
10mm			510-2	175-5102	175-5102-10W
12mm			512-2	175-5122	175-5122-10W

**ELECTRODES**

**Stud Electrodes**

Tuffaloy stud electrode tips are for projection-welding screws, bolts or pins, whether they pass through the sheet or are to be attached directly to its face.

**Nut Electrodes**

Tuffaloy projection weld nut electrodes are designed for either self-piloted or non-piloted nuts. The pilots of the non-piloted-nut electrodes are spring-loaded so they can't interfere with the contacting of nut and sheet under welding pressure.

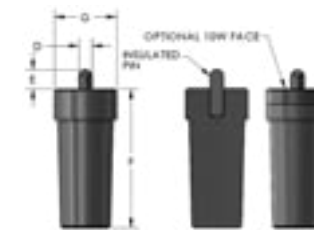

**SELF-PILOTED-NUT ELECTRODES**

D For Nut Size	E Pin Length	F Electrode Length	G Electrode Diameter	Description	Part No.	With 10W Face Refractory - Item Number
#08 (.164)	3/16	2-1/4	1	411	175-4111	175-4111-10W
#10 (.190)	3/16			412	175-4121	175-4121-10W
#12 (.216)	1/4			413	175-4131	175-4131-10W
1/4	5/16			414	175-4141	175-4141-10W
5/16 & 8mm	5/16			415	175-4151	175-4151-10W
3/8	3/8			416	175-4161	175-4161-10W
6mm	1/4			606	175-6061	175-6061-10W
7mm	5/16			607	175-6071	175-6071-10W
9mm	3/8			609	175-6091	175-6091-10W
10mm	3/8			610	175-6101	175-6101-10W
3/8	3/8			2-3/4	1-1/2	456
7/16	3/8	457	175-4571			175-4571-10W
1/2	7/16	458	175-4581			175-4581-10W
9/16	7/16	459	175-4591			175-4591-10W
5/8	1/2	460	175-4601			175-4601-10W
11/16	1/2	461	175-4611			175-4611-10W
3/4	5/8	462	175-4621			175-4621-10W
10mm	3/8	610-2	175-6102			175-6102-10W
12mm	7/16	612-2	175-6122			175-6122-10W

**NON-PILOTED-NUT ELECTRODES**

H For Nut Size	J Pin Diameter	K Electrode Length	L Electrode Diameter	Description	Part No.	With 10W Face Refractory - Item Number
#08 (.164)	0.18	2-1/4	1	421	175-4211	175-4211-10W
#10 (.190)	0.215			422	175-4221	175-4221-10W
#12 (.216)	0.24			423	175-4231	175-4231-10W
1/4	0.275			424	175-4241	175-4241-10W
5/16 & 8mm	0.345			425	175-4251	175-4251-10W
3/8	0.405			426	175-4261	175-4261-10W
6mm	0.261			706	175-7061	175-7061-10W
7mm	0.3			707	175-7071	175-7071-10W
9mm	0.385			709	175-7091	175-7091-10W
10mm	0.425			710	175-7101	175-7101-10W
3/8	0.437			2-3/4	1-1/2	476
7/16	0.562	477	175-4771			175-4771-10W
1/2	0.625	478	175-4781			175-4781-10W
9/16	0.687	479	175-4791			175-4791-10W
5/8	0.75	480	175-4801			175-4801-10W
10mm	0.453	710-2	175-7102			175-7102-10W
12mm	0.595	712-2	175-7122			175-7122-10W

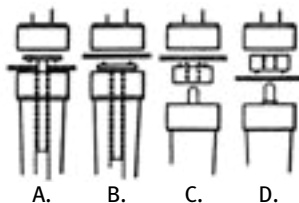

- A. Welding a stud through a hole in sheet metal.
- B. Welding a stud directly to face of sheet metal.
- C. Self-piloted nut aligns itself with the hole in sheet.
- D. Non-piloted-nut is guided by specially designed electrode.



# TUFFALOY NUT AND STUD WELDING

## ELECTRODE HOLDERS

U.S. Pat. No. 3,504,159 Canada Pat. No. 858,060

Tuffaloy Straight and Offset electrode holders are manufactured to accommodate all the nut and stud electrode lengths.

### STRAIGHT NUT AND STUD WELDING HOLDERS

Shank OD	A Dia.	B Length	For 1" Dia. Electrodes		For 1-1/2" Dia. Electrodes	
			Description	Part No.	Description	Part No.
1	1-3/4	5-5/8	4530	350-4530		
1-1/4	1-3/4	5-5/8	4531	350-4531		
1-1/2	1-3/4	5-5/8	4532	350-4532		
1	2	5-3/4			4535	350-4535
1-1/4	2	5-3/4			4536	350-4536
1-1/2	2	5-3/4			4537	350-4537

### OFFSET NUT AND STUD WELDING HOLDERS

Shank OD	For 1" Dia. Electrodes		For 1-1/2" Dia. Electrodes	
	Description	Part No.	Description	Part No.
1	4540	350-4540		
1-1/4	4541	350-4541	4546	350-4546
1-1/2	4542	350-4542	4547	350-4547

**Straight and Offset Holders** - Tuffaloy straight and offset nut and stud electrode holders are of the same high quality as the standard straight holders made for spot welder arm mounting. Coolant is brought to the tip and circulated around it. Holders are available in three barrel diameters.

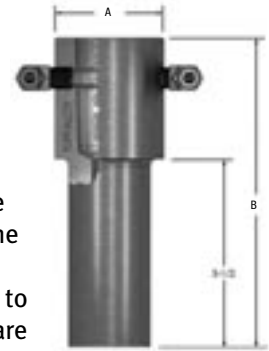

Straight Holder

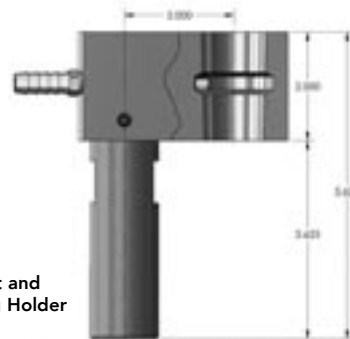

Offset Nut and Stud Welding Holder

## ARCTIC HOLDERS

### ARCTIC STUD ELECTRODES

A For Stud Diameter	B Electrode Length	C Electrode Diameter	Description	Part Number	Shank Size		
#06 (.150)	3	1-1/4	115	175-1151-X			
#08 (.164)			116	175-1161-X			
#10 (.190)			119	175-1191-X			
#12 (.216)			122	175-1221-X			
1/4			125	175-1252-X			
5/16 & 8mm			131	175-1312-X			
3/8			138	175-1382-X			
7/16			144	175-1442-X			
6mm			106	175-1061-X			
7mm			107	175-1071-X			
9mm			109	175-1092-X			
10mm			110	175-1102-X			
1/2			3	1-1/2	150	175-1503-X	
9/16					156	175-1563-X	
5/8	163	175-1633-X					
11/16	169	175-1693-X					
12mm	112	175-1123-X					

**Arctic Electrodes** - The Arctic system is a compact stud-and-nut electrode with internal water cooling. Also available with optional air expulsion and platen mounts.

Patent Pending

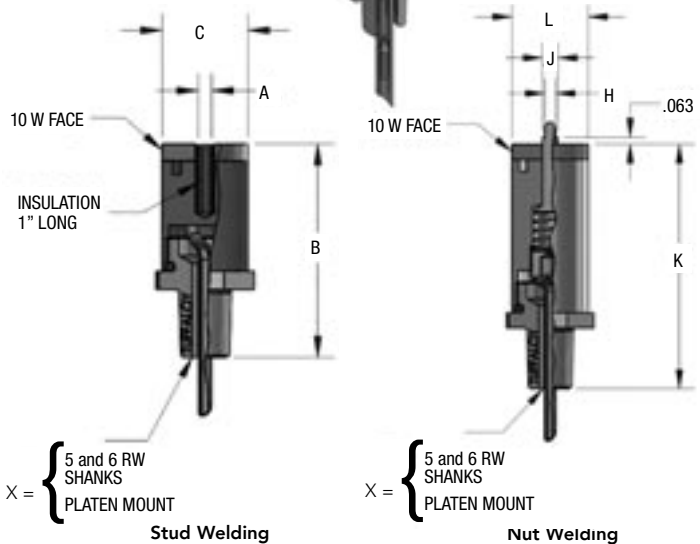

Stud Welding

Nut Welding



**METRIC NUT ELECTRODES**

TUFFALOY now stocks the head/pin style welding system components that adds to your selection for stud and nut welding needs. For a complete and updated listing of electrodes that will best meet your needs visit [tuffaloy.com/products/nut-and-stud-welding](http://tuffaloy.com/products/nut-and-stud-welding).

**Heads** are made from RWMA Class 2 (C18200) alloy that are an optimal performance consumable. Class 2 (C18200) with 10W (copper tungsten) face are available for longer life. With a concave seat the pin locates in the center of assembly when air is applied to the system. This gives you a repeatable location for automated nut feeders to introduce the nut to the environment.

**Pins** have a nonconductive surface on a steel matrix that gives longer life in a repetitive motion environment. With the threaded head securing the pin in place it makes it easy to replace the pin to meet your requirements. TUFFALOY can design pins for special applications.

HEADS					
Part Number	Hole Dia.	A Pin Size	B Thread	C Dia.	Copper-Tungsten Faced Heads
175-8004	.197"	4mm	M18	1.0"	175-8004-10W
175-8005	.236"	5mm			175-8005-10W
175-8006	.276"	6mm			175-8006-10W
175-8007	.315"	7mm			175-8007-10W
175-8008	.354"	8mm			175-8008-10W
175-8009	.394"	9mm			175-8009-10W
175-8010	.432"	10mm	M22	1.125"	175-8010-10W
175-8011	.472"	11mm			175-8011-10W
175-8012	.512"	12mm			175-8012-10W
175-8013	.551"	13mm			175-8013-10W
175-8014	.588"	14mm	M26	1.250"	175-8014-10W
175-8015	.625"	15mm			175-8015-10W



PINS				
Part Number	A Nut	B OAL	C Base	Pilot Dia.
195-3004	4mm	1.12"	12mm	.185"
195-3005	5mm	1.17"		.224"
195-3006	6mm	1.23"		.264"
195-3007	7mm	1.24"		.303"
195-3008	8mm	1.25"		.340"
195-3009	9mm	1.19"		.380"
195-3010	10mm	1.37"	16mm	.422"
195-3011	11mm	1.38"		.458"
195-3012	12mm	1.40"		.500"
195-3013	13mm	1.37"		.539"
195-3014	14mm	1.50"	.815"	.580"
195-3015	15mm	1.52"		.620"



BODIES					
Description	Part Number	A OAL	B Dia.	C Thread	D Taper/Thread
TDH-25A	301-0004	1.77"	1"	18mm	#4
TDH-25C	301-0005	1.97"	1"	18mm	#5
TDH-25C-THD	301-0006	2.13"	1"	18mm	5/8-11
TDH-30A	301-0015	1.97"	1.125"	22mm	#5
TDH-35A	301-0020	1.97"	1.25"	26mm	#5

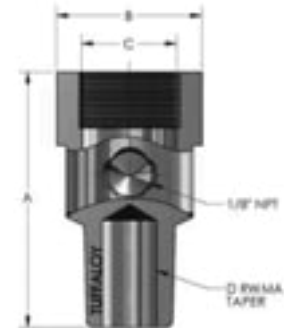

UPPER ELECTRODE						
Description	Part Number	A ID	B OAL	C Dia.	D Taper	Copper-Tungsten Faced Heads
TNFD 16-M5-16-3	186-0101	5mm	2.36"	.625"	5RW	186-0101-10W
TNFD 20-M6-16-3	186-0102	6mm		.75"		186-0102-10W
TNFD 20-M8-16-3	186-0103	7.5mm		.75"		186-0103-10W
TNFD 20-M10-16-3	186-0104	10mm		.75"		186-0104-10W
TNFD 20-M12-16-3	186-0105	12mm		.75"		186-0105-10W



**GH SERIES NUT WELDING HEADS**

Tuffaloy's Evolution™ GH series Nut Welding Heads are designed for long life, wear resistance and insulation against arcing. Custom lengths, weld faces and diameters available.

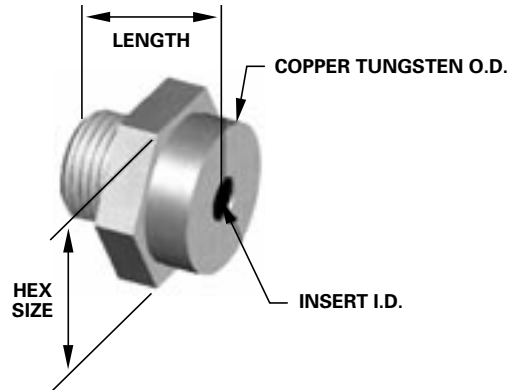

	GH-2 Series	GH-3 Series	GH-4 Series	Insert I.D.
Length	0.875	1.000	1.125	
Tungsten OD	0.875	1.250	1.500	
Hex Size	1.000	1.375	1.625	
Thread Size	5/8-18	7/8-14	1 1/8-12	
	175-GH-2-188-SS	175-GH-3-188-SS		0.188
	175-GH-2-193-SS	175-GH-3-193-SS		0.193
	175-GH-2-197-SS			0.197
		175-GH-3-200-SS		0.200
	175-GH-2-212-SS			0.212
	175-GH-2-218-SS			0.218
	175-GH-2-239-SS			0.239
	175-GH-2-240-SS			0.240
	175-GH-2-242-SS	175-GH-3-242-SS		(6mm) 0.242
	175-GH-2-245-SS	175-GH-3-245-SS		0.245
		175-GH-3-247-SS		0.247
	175-GH-2-250-SS			0.250
		175-GH-3-251-SS		0.251
	175-GH-2-252-SS			0.252
		175-GH-3-254-SS		0.254
	175-GH-2-258-SS			0.258
		175-GH-3-262-SS		0.262
	175-GH-2-263-SS			0.263
		175-GH-3-264-SS		0.264
	175-GH-2-272-SS	175-GH-3-272-SS		0.272
	175-GH-2-273-SS	175-GH-3-273-SS		0.273
	175-GH-2-275-SS			0.275
	175-GH-2-277-SS			0.277
		175-GH-3-278-SS		0.278
	175-GH-2-280-SS			0.280
	175-GH-2-282-SS			0.282
	175-GH-2-287-SS			0.287
	175-GH-2-292-SS			0.292
		175-GH-3-295-SS		0.295
	175-GH-2-312-SS	175-GH-3-312-SS		0.312
		175-GH-3-317-SS		(8mm) 0.317
	175-GH-2-322-SS	175-GH-3-322-SS		0.322
	175-GH-2-325-SS		175-GH-4-325-SS	0.325
		175-GH-3-326-SS		0.326
		175-GH-3-332-SS		0.332
		175-GH-3-337-SS		0.337
				0.342
		175-GH-3-347-SS		0.347
		175-GH-3-351-SS	175-GH-4-351-SS	0.351
		175-GH-3-352-SS		0.352
				0.354
		175-GH-3-357-SS		0.357

GH-2 Series	GH-3 Series	GH-4 Series	Insert I.D.
0.875	1.000	1.125	
0.875	1.250	1.500	
1.000	1.375	1.625	
5/8-18	7/8-14	1 1/8-12	
175-GH-2-359-SS			0.359
175-GH-2-368-SS			0.368
175-GH-2-372-SS	175-GH-3-372-SS		0.372
	175-GH-3-392-SS		0.392
	175-GH-3-397-SS		(10mm) 0.397
	175-GH-3-412-SS		0.412
	175-GH-3-417-SS		0.417
	175-GH-3-423-SS		0.423
	175-GH-3-425-SS		0.425
	175-GH-3-427-SS		0.427
	175-GH-3-430-SS		0.430
	175-GH-3-432-SS		0.432
	175-GH-3-437-SS		0.437
	175-GH-3-445-SS		0.445
	175-GH-3-447-SS		0.447
	175-GH-3-452-SS		0.452
	175-GH-3-465-SS		0.465
	175-GH-3-467-SS		0.467
	175-GH-3-470-SS		0.470
	175-GH-3-472-SS		0.472
	175-GH-3-480-SS		(12mm) 0.480
	175-GH-3-504-SS		0.504
	175-GH-3-507-SS		0.507
	175-GH-3-508-SS		0.508
		175-GH-4-509-SS	0.509
	175-GH-3-512-SS		0.512
	175-GH-3-517-SS		0.517
	175-GH-3-522-SS		0.522
		175-GH-4-532-SS	0.532
	175-GH-3-534-SS		0.534
	175-GH-3-538-SS		0.538
	175-GH-3-542-SS		0.542
	175-GH-3-547-SS		0.547
	175-GH-3-548-SS		0.548
	175-GH-3-552-SS		0.552
	175-GH-3-557-SS		0.557
			0.587
			0.592
			0.632
			0.656
		175-GH-4-667-SS	0.667
		175-GH-4-677-SS	0.677



Tuffaloy's stainless steel centering pins for use with GH series Nut Welding Heads.

Pin Part Number	Nut Size	Head Size	Pilot Diameter	Pin Diameter	Mating Head Part Number
178-2-228-143	#10	GH-2	0.228	0.143	175-GH-2-242
178-2-298-192	1/4	GH-2	0.298	0.192	175-GH-2-312
178-2-343-257	5/16	GH-2	0.343	0.257	175-GH-2-357
178-2-248-186	6mm	GH-2	0.248	0.186	175-GH-2-261
178-2-338-252	8mm	GH-2	0.338	0.252	175-GH-2-352
178-3-228-143	#10	GH-3	0.2288	0.143	175-GH-3-242
178-3-298-192	1/4	GH-3	0.298	0.192	175-GH-3-312
178-3-343-257	5/16	GH-3	0.343	0.257	175-GH-3-357
178-3-409-306	3/8	GH-3	0.409	0.306	175-GH-3-423
178-3-490-316	7/16	GH-3	0.490	0.316	175-GH-3-504
178-3-248-186	6mm	GH-3	0.248	0.186	175-GH-3-262
178-3-338-252	8mm	GH-3	0.338	0.252	175-GH-3-352
178-3-398-322	10mm	GH-3	0.398	0.322	175-GH-3-412
178-3-466-388	12mm	GH-3	0.4668	0.388	175-GH-3-480

EXAMPLE PART NUMBER: 178-3-343-257



WHEN SPECIFYING A PIN AND GH HEAD COMBO, ALLOW .005" TO .010" GAP PER SIDE BETWEEN THE PILOT DIAMETER AND THE GH HEAD HOLE DIAMETER

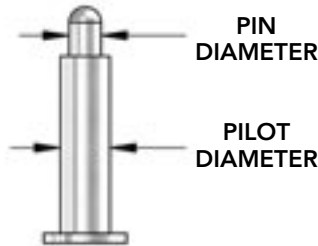

PILOT DIAMETER LENGTH IS BASED ON GH HEAD SIZE  
 PIN DIAMETER LENGTH IS BASED OFF OF NUT SIZE



# TUFFALOY 5 RW STUD ELECTRODES

These series of Stud electrodes are made from RWMA Class 2 (C18200) alloy with 10W (copper tungsten) on the weld face and wrench flats for easy removal from holders. The Insulator is made to withstand the constant friction that is applied as the stud is inserted and removed.

Screw Thread Size	INSULATOR		Part Number
	ID. A	Length B	
#10 6mm 1/4 5/16, 8mm 3/8 10mm	.218	1"	175-0316-4032-10W
	.243		175-0316-40062-10W
	.256		175-0316-4042-10W
	.319		175-0316-4052-10W
	.381		175-0316-4062-10W
.400	175-0316-40102-10W		
#10 6mm 1/4 5/16, 8mm 3/8 10mm	.218	2"	175-0316-4031-10W
	.243		175-0316-4006-10W
	.256		175-0316-4041-10W
	.319		175-0316-4051-10W
	.381		175-0316-4061-10W
.400	175-0316-4010-10W		
7/16 12mm 1/2 9/16 5/8 11/16 3/4	.444	1"	175-1313-4372-10W
	.479		175-1313-40122-10W
	.506		175-1313-4382-10W
	.569		175-1313-4392-10W
	.652		175-1313-4402-10W
	.694		175-1313-4412-10W
.777	175-1313-4422-10W		
7/16 12mm 1/2 9/16 5/8 11/16 3/4	.444	2"	175-1313-4371-10W
	.479		175-1313-4012-10W
	.506		175-1313-4381-10W
	.569		175-1313-4391-10W
	.652		175-1313-4401-10W
	.694		175-1313-4411-10W
.777	175-1313-4421-10W		

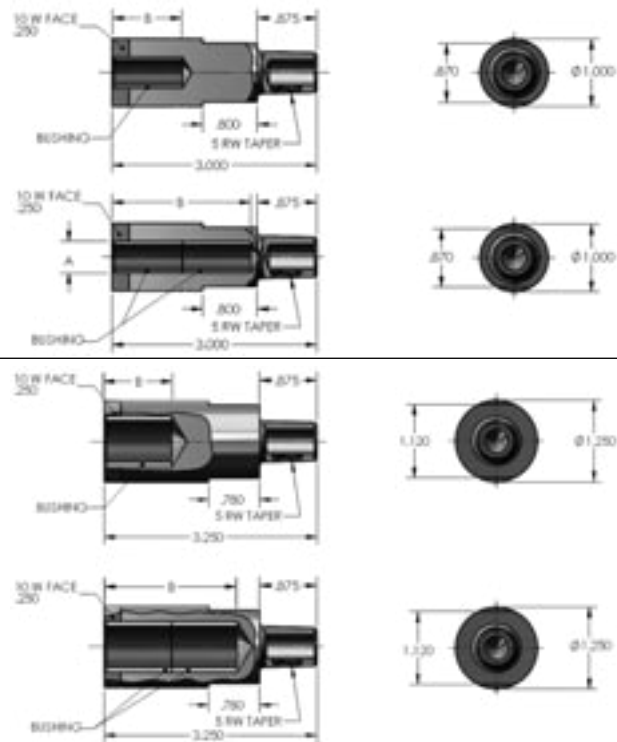

## BACKUP ELECTRODES FOR UPPERS

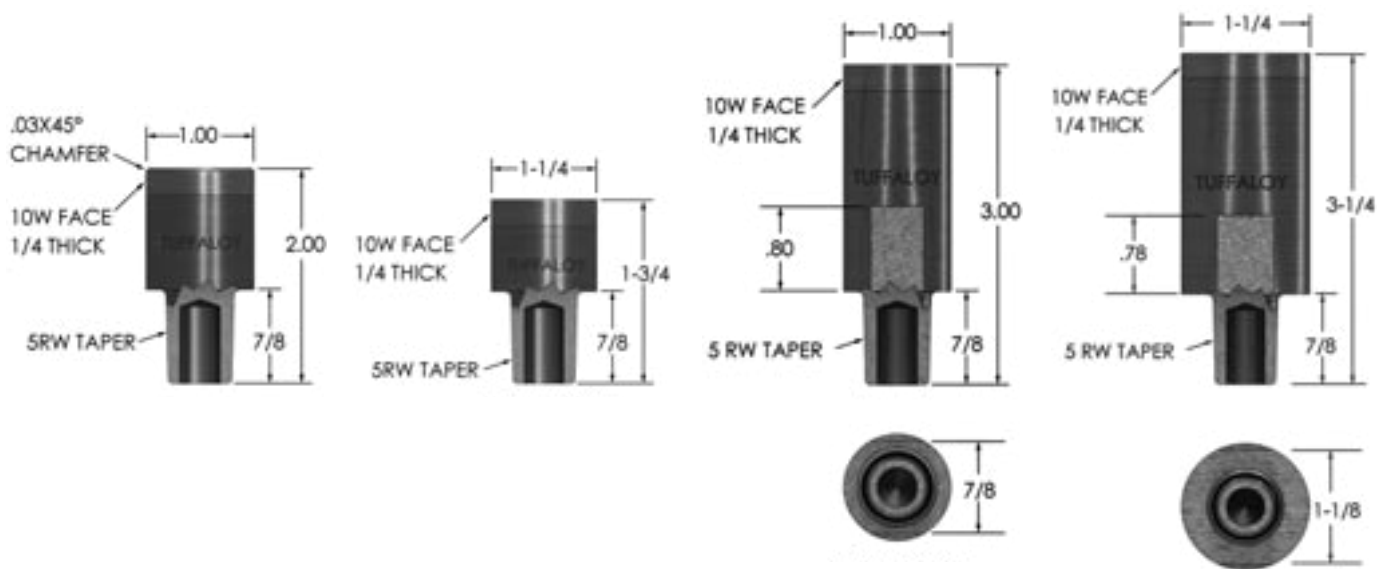

186-0311-10W

186-0313-10W

186-0316-10W

186-1313-10W



QUICKEST WAY TO CUT WELDING COSTS

Increased productivity without capital investment or increased labor costs just has to spell PROFIT. Hundreds of resistance welding users are profiting from the TUFFALOY methods of multiple welding, to produce almost any assembly requiring closely spaced welds.

The key is to “think multiple!” Whenever the welding machine goes through a cycle, have it do more than one weld at a time. It’s easy and practical with one of the TUFFALOY multiple welding devices: The Teeter-Tip dual tip adapter, the Equatip dual tip holder, the Equa-Press dual tip holder, or the Tri-Spacer.

They’re ready to go to work, cutting costs and increasing production efficiency for you.

Study the multiple welding holders and adapters in this section. Learn their capabilities, “think multiple,” and you’ll probably see many ways in which TUFFALOY multiple welding solutions can improve your operation. Remember that TUFFALOY is prepared to provide any special fixturing you need. Show our engineers what you require, and they’ll design a set-up to do it.

TEETER-TIP DUAL TIP ADAPTERS

U.S. Pat. 3,356,821

You can spot or projection weld in half the time by doubling the number of welds per machine stroke. Use Teeter-Tip dual tip adapters, which come with water-coolant fittings to beat high heat build-up. These adapters transmit total pressures of 1000 lbs., and deliver equal current and pressure to each tip. They compensate for normal electrode wear, imperfect tip dressing, and work variations up to .060”.

**LIGHT-DUTY** adapters are available with No. 4 or 5 RW shanks to mount the holder to a barrel or other electrode holder. The Teeter-Tip holder is designed to hold male TUFFCAPS or 4 RW tips. The tips can be spaced up to 4 inches apart.

**HEAVY-DUTY** adapters are available with No. 5 to 7 RW shanks to mount the holder to a barrel or other electrode holder. The Teeter-Tip holder is designed to hold male TUFFCAPS or 4 RW tips. The tips can be spaced up to 6 inches apart.

Two low-height 5/8” dia. cap-type tips are shown below. They are recommended for use in these adapters. All the available socket taper options for the tips are shown in the table below. You must specify the size tip sockets you want, or the standard socket will be supplied.

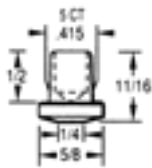

TRUNCATED CONE SE-6332 (Part No. 186-0522)

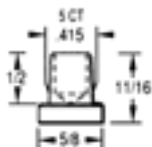

FLAT FACED SE-6296 (Part No. 186-0523)

Style	S Shank Taper	Description*	L Tip Spacing Range (inches)	T Socket Taper
LIGHT Duty	4RW	TT-1408	1-1/4 to 2	4RW 4CT 5CT
	4RW	TT-1416	2 to 4	4RW 4CT 5CT
	5RW	TT-1508	1-1/2 to 2	4RW 4CT 5CT
	5RW	TT-1516	2 to 4	4RW 4CT 5CT
HEAVY Duty	5RW	TT-15516	2 to 4	4RW 5RW 4CT 5CT
	5RW	TT-15524	4 to 6	4RW 5RW 4CT 5CT
	6RW	TT-15616	2 to 4	4RW 5RW 4CT 5CT
	6RW	TT-15624	4 to 6	4RW 5RW 4CT 5CT
	7RW	TT-15716	2 to 4	4RW 5RW 4CT 5CT
	7RW	TT-15724	4 to 6	4RW 5RW 4CT 5CT

\*When ordering, also state exact tip spacing and tip socket size, Example: TT-1508-1.500-5CT. (5CT means 5/8” diameter cap, 4CT means 1/2” diameter cap.)

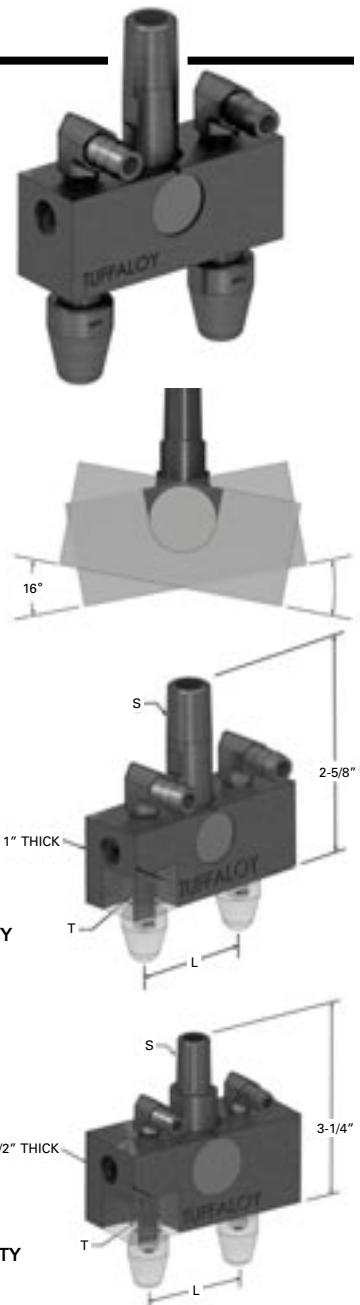

## EQUATIP DUAL TIP HOLDERS

U.S. Pat. No. 3,558,847

The Equatip dual tip holder is a smaller version of the Equa-Press holder (on next page). It is more compact, and is more economical for those applications where it will work equally well. An even smaller device, the Equatip Adapter (not water-cooled) is shown in box below.

Using the Equatip holder, both tips contact the work squarely, because tip axes remain parallel to direction of force (unlike the Teeter-Tip adapters). An internal roller equalizes current and pressure between the two electrodes, and will compensate for work height variations up to 1/16".

The holders are ordered with either 1" or 1-1/2" spacing between barrels, and with tip sockets to accept either male Tuffcap caps (5/8" dia.) or straight No. 4 RW electrodes. (Bent tips are not recommended.) The distance between welds can be varied by rotating offset D-nose tips in the barrels.

Equatip holders can be supplied with straight shanks for arm mounting, a tapered adapter shank for holder mounting, or a cylinder adapter shank to be clamped to a cylinder rod. Special width spacing is available as a special item.

Equatip holders can be used with forces up to 1000 lbs.

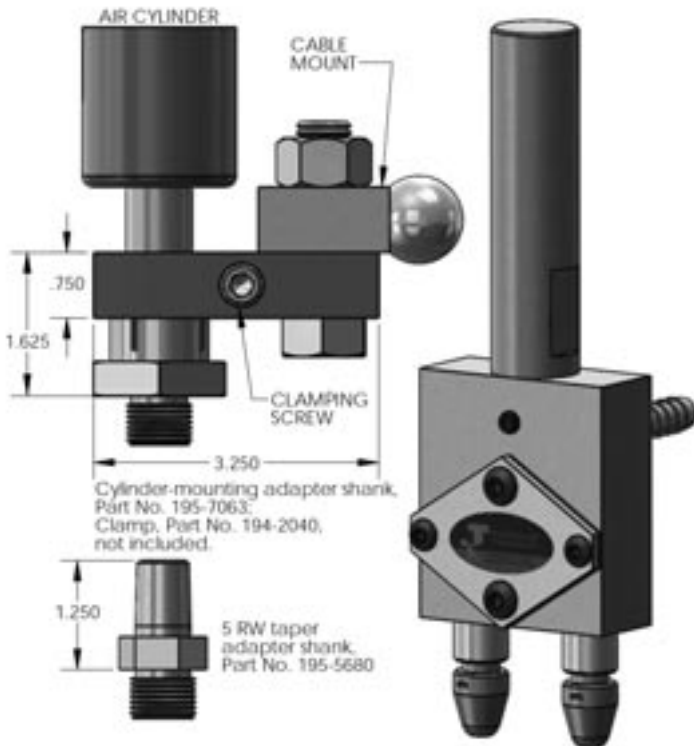

EQUATIP HOLDERS				
Tip Spacing & Mounting Style	For 5/8" Dia. Tuffcap Caps		For No. 4 RW Tips	
	Description	Part No.	Description	Part No.
<b>ONE-INCH SPACING:</b>				
1-in. shank	4050	350-4050	4055	350-4055
1-1/4-in. shank	4051	350-4051	4056	350-4056
1-1/2-in. shank	4052	350-4052	4057	350-4057
5RW adapter	4053	350-4053	4058	350-4058
Cylinder adapter*	4054	350-4054	4059	350-4059
<b>1-1/2-INCH SPACING:</b>				
1-in. shank	4150	350-4150	4155	350-4155
1-1/4-in. shank	4151	350-4151	4156	350-4156
1-1/2-in. shank	4152	350-4152	4157	350-4157
5RW adapter	4153	350-4153	4158	350-4158
Cylinder adapter*	4154	350-4154	4159	350-4159

\*Without clamp

5/8" DIA. TUFFCAP CAPS (5 CT)			
Nose Style	Alloy Class	Description	Part No.
Pointed	1	TA-15	111-0015
	2	TA-25	112-0025
Dome	1	TB-15	113-0015
	2	TB-25	114-0025
Flat	1	TC-15	115-0015
	2	TC-25	116-0025
Offset	1	TD-15	117-0015
	2	TD-25	118-0025

Those caps are fully dimensioned on page 8.

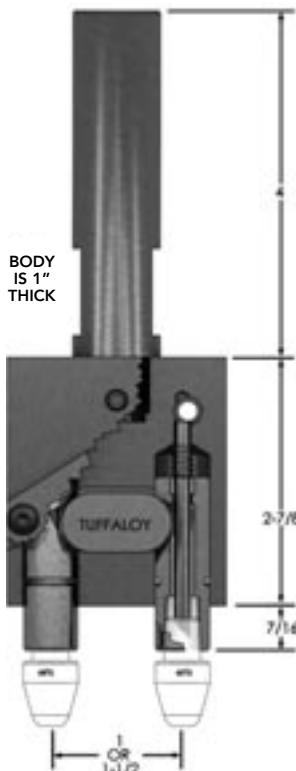

## For light-duty welding EQUATIP ADAPTER

The Equatip dual tip adapter works like the Equatip holder, but it is not water-cooled and is meant for less demanding jobs. Due to spacing, only No. 4 RW TUFFCAPS can be used (1/2" diameter caps).

1/2" DIA. TUFFCAP CAPS (4 CT)			
Nose Style	Alloy Class	Description	Part No.
Pointed	1	TA-14	111-0014
	2	TA-24	112-0024
Dome	1	TB-14	113-0014
	2	TB-24	114-0024
Flat	1	TC-14	115-0014
	2	TC-24	116-0024
Offset	1	TD-14	117-0014
	2	TD-24	118-0024

Those caps are fully dimensioned on page 8.

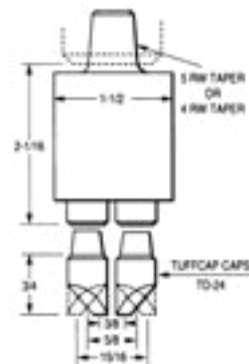

4045, Part No. 350-4045-5RW  
4046, Part No. 350-4046-4RW







**EQUA-PRESS™  
DUAL TIP  
HOLDERS**  
U.S. Pat. No. 2,979,599  
Canada Pat. 637470

The Equa-Press Holder makes two identical welds at once. When it contacts the workpiece, the forging pressure is automatically equalized between the two electrodes, regardless of variations in work thickness, or electrode wear (up to 3/16"). The two tip-holding barrels are sliding pistons, whose movements are controlled by a mechanical equalizing slide in the housing (see cutaway drawings). The spring's only function is to return the barrels to a fully extended position when there is no work contact. Maximum conductivity is maintained through sturdy copper alloy working parts. Spacing can vary up to 4 inches, using TUFFALOY bent offset tips in Equa-Press holders having the standard barrel spacing of two inches (shown).

Barrel spacing up to six inches is available as semi-standard. These are drilled to order from stock components. To order you must give the barrel spacing desired, along with the Item number (from table).

Equa-Press Holders are made in two mounting styles: platen models to mount directly to the platen on press-type welding machines, and shank models for rocker arm machines. All are available in two designs: the standard and the short (close-coupled) type. The short design is internally flood-cooled and takes up less space in the welder.

Equa-Press holders can be used with forces up to 1500 lbs.

Mounting Style	Standard Design		Short Design	
	Descrip-tion	Part No.	Descrip-tion	Part No.
1-in. shank	4010	350-4010	4015	350-4015
1-1/4-in. shank	4011	350-4011	4016	350-4016
1-1/2-in. shank	4012	350-4012	4017	350-4017
Platen	4013	350-4013	4018	350-4018

*Note: For best results, position the holder so that a line drawn through the electrode centers is at, or nearly at, right angles to the direction of the welder arms. Otherwise, the magnetic field between the arms can cause an excess of current to flow through the inboard electrode.*

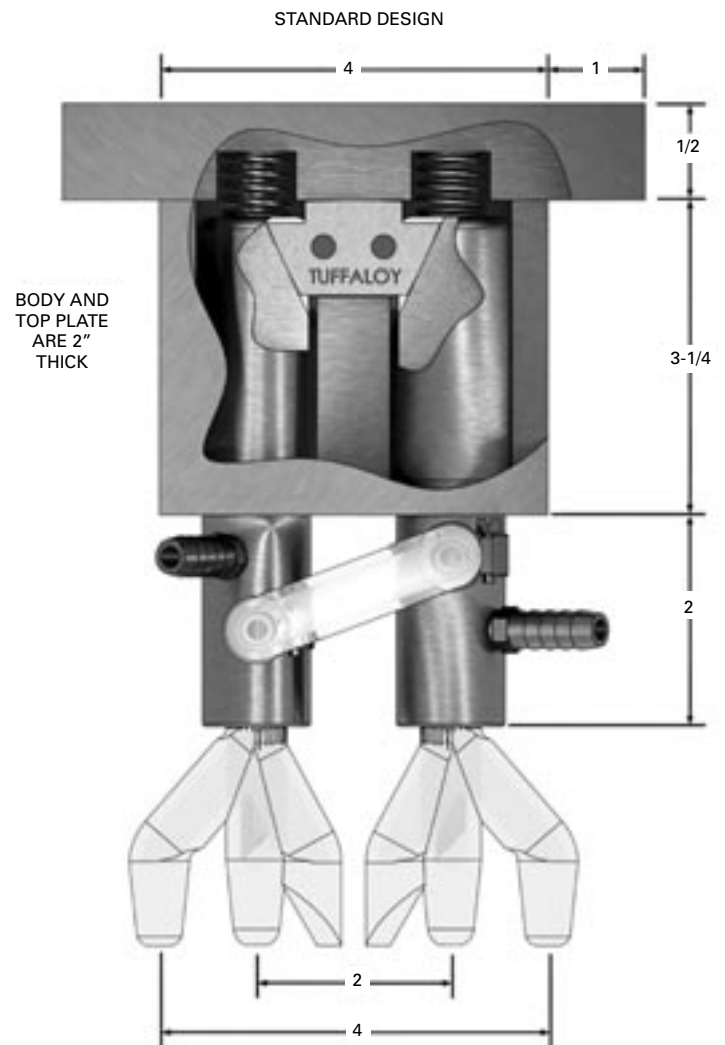
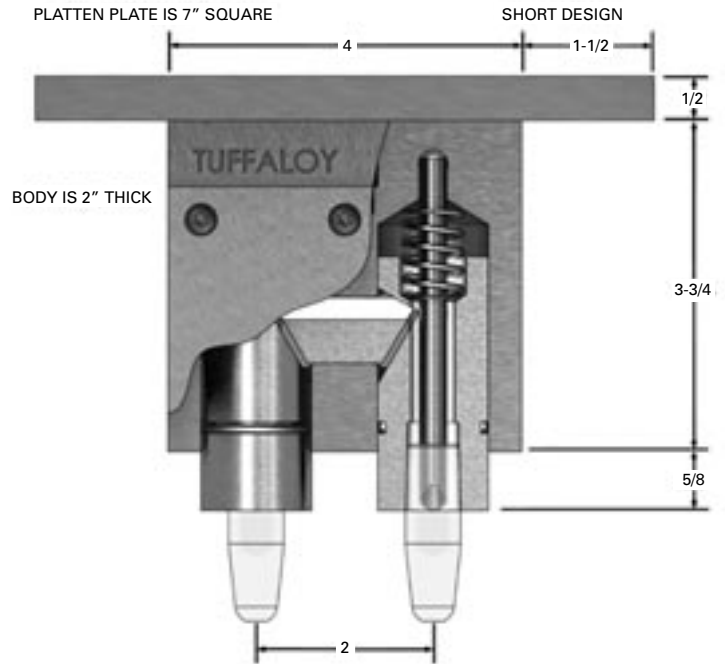

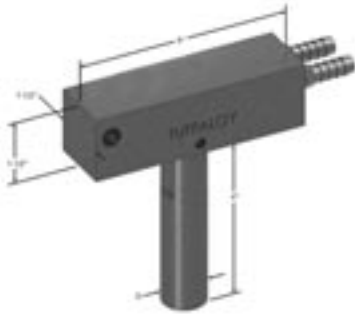

## LOWER ELECTRODES

D Shank Diameter	Description	Part No.
1	4020	350-4020
1-1/4	4021	350-4021
1-1/2	4022	350-4022

## LOWER HOLDERS AND ELECTRODES FOR USE WITH EQUA-PRESS HOLDER

A lower, fixed, dual tip holder is offered for use with Equa-Press Holders. Like the Equa-Press, it has a standard two-inch tip spacing and helps make two welds at once, precisely alike. The standard transverse bar electrode shown is used when work geometry doesn't require tips on the lower side. They are both water-cooled.

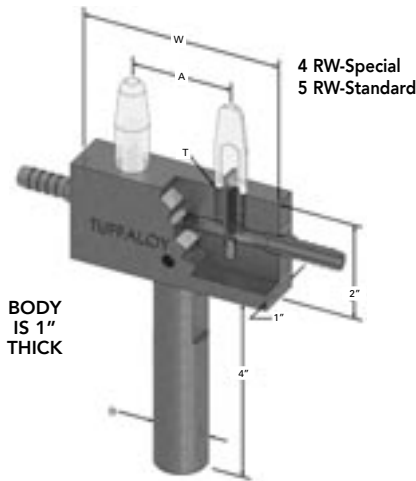

## STANDARD LOWER HOLDER - 2" SPACING 5 RW

D Shank Diameter	Lower Holder	
	Description	Part No.
1	4030	350-4030
1-1/4	4031	350-4031
1-1/2	4032	350-4032

## SPECIAL LOWER ELECTRODES

W Style	D Shank Diameter (inches)	Description*	A Tip Spacing Range (inches)
4" Body	1	4030	1-1/4 to 2-7/8
	1-1/4	4031	1-1/4 to 2-7/8
	1-1/2	4032	1-1/4 to 2-7/8
8" Body	1	8030	3 to 6
	1-1/4	8031	3 to 6
	1-1/2	8032	3 to 6

\*When ordering specify center distance and either 4RW or 5 RW sockets



*A Case Study: Projection welding brackets to automotive frame assemblies is twice as fast with an Equa-Press dual tip holder. Lower welding fixture acts as an inspection device, so warped parts are discovered before welding. Inspection time and scrap loss are both reduced.*



*A Case Study: Joining a piece of metal to itself is always tough. This job was done with an Equa-Press holder - two at a time. Lower clamp faces, carrying current, contact parts near the weld areas to avoid current bypassing weld projections. Two standard swivel tips make four welds, two per part.*



*A Case Study: Dual spot welding of panelled wall sections reduced welding costs enough to justify buying welding machine to do the job in-plant. Equa-Press holder with 5-inch spacing, and special (but simple) tooling to provide two offset tip adapters and matching holders were used. Electrodes are standard TUFFCAP caps.*

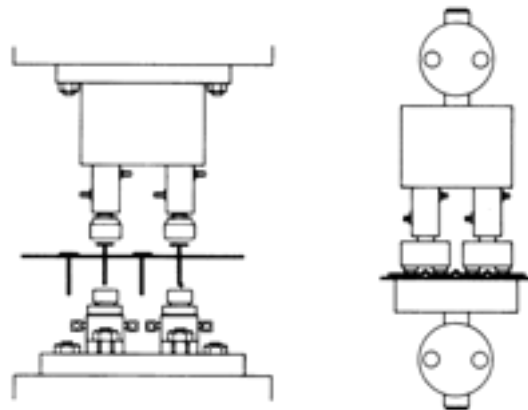

*In this drawing, two studs are projection welded in each welder stroke, using an Equa-Press dual holder over a pair of studwelding electrodes held in PM-style holders.*

*Here, four spot welds are made simultaneously on a corrugated part. An Equa-Press dual holder is used to hold two Teeter-Tip dual tip adapters.*



**TRISPACER HOLDER**

Mounting Style	Description	Part No.
1-in. shank	4040	350-4040
1-1/4-in. shank	4041	350-4041
1-1/2-in. shank	4042	350-4042
Platen	4043	350-4043

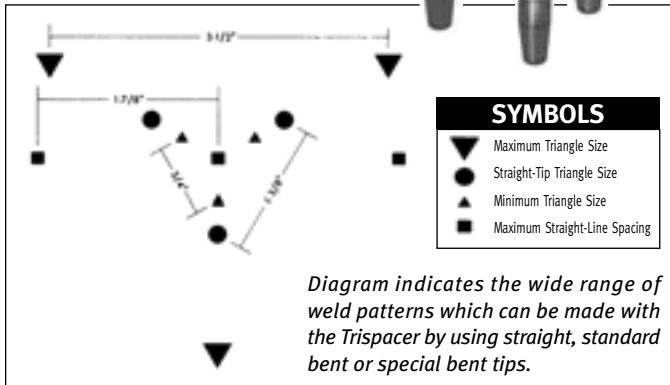

**TRISPACER™ TRIPLE TIP HOLDER**

*U.S. Pat. No. 3,558,848*

The Trispacer tip holder will make three spot welds at one time, automatically splitting the current and the pressure equally between the three tips. In doing so, it compensates for variations in work thicknesses and electrode wear-up to 3/16-in.

The three tip-holder barrels (#5 RW) are equidistant from one another, all falling on a 1-5/8 inch diameter circle (in the standard model shown). Using straight tips the weld pattern would form an equilateral triangle. However, the weld pattern can be widely varied by using standard or special bent tips. In fact, the three welds can be made in a straight line.

The Trispacer Holder works in the same simple, mechanical way as the Equa-Press Holder: The tip-holding barrels have a limited up-and-down movement, to accommodate work conditions, and are adjusted to deliver equal pressure by the cone-shaped equalizing device in the housing. All current-carrying parts are made of RWMA copper alloys. It is made in two styles: to mount directly to the platen of press-type welders, and with shanks to fit in welder arms.

Trispacer Holders can be used with forces up to 2000 lbs.

**LOWER ELECTRODE**

A simple, water-cooled lower electrode is made for use with the Trispacer holder. Its three-inch-diameter face makes it usable with any weld pattern that may be developed for the Trispacer. It comes in three shank diameter models.

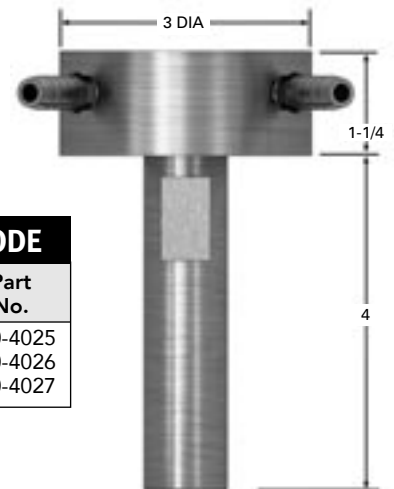
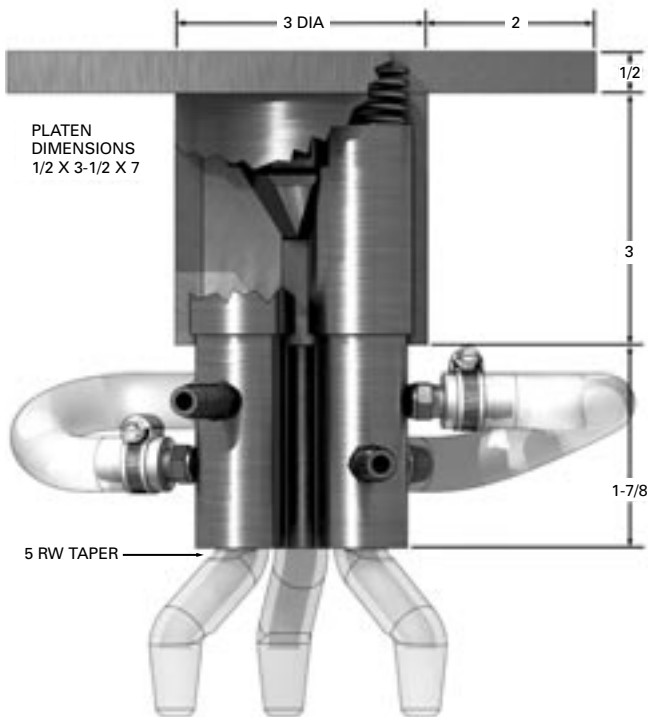

**LOWER ELECTRODE**

Shank Dia.	Description	Part No.
1	4025	350-4025
1-1/4	4026	350-4026
1-1/2	4027	350-4027



# TUFFALOY FAST FOLLOW-UP HOLDERS

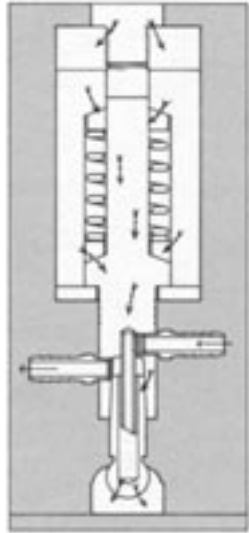

Current flow follows dashed arrow through the outer body, two split contact rings, tapered tip socket, and to the electrode.

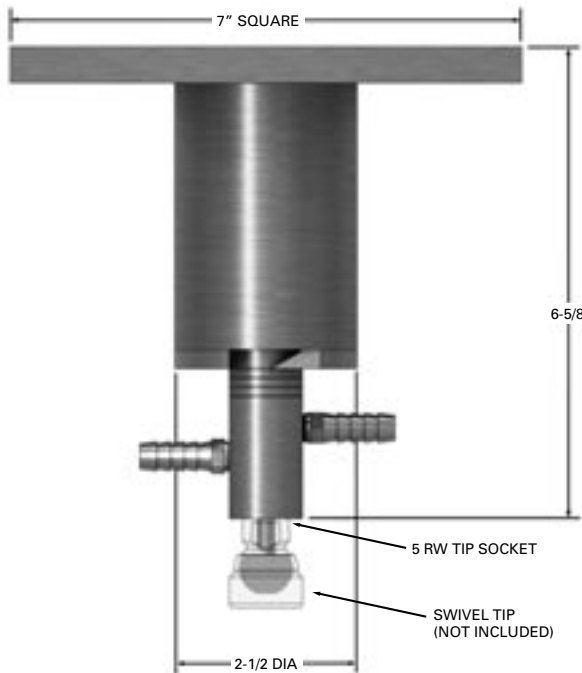

U.S. Pat. No. 3,632,958 Canada Pat. No. 902,189

TUFFALOY fast follow-up (low inertia) holders solve the problem of maintaining adequate weld pressure on rapidly collapsing projection welds-with fewer set-up problems and reduced maintenance.

These holders can be set to deliver fast follow-up forces ranging from 140 to 1300 pounds, a range covering 90% of all projection welding operations. They are compact, water cooled, and easy to maintain.

Plus features of the TUFFALOY fast follow-up holder include: (1) wider range of pressures than any competitive make (2) no flexible shunt (a common cause of holder failure) (3) use of standard, unmodified die springs, so if you need a spring of different strength, it's easily available (4) spring forces available are clearly indicated, so it's easy to set up for a specific force (5) three shank sizes, or it can be platen-mounted-the only fast follow-up holder that can (6) extremely low height permits use where larger units can not be used.

TUFFALOY fast follow-up holders can be used to limit the weld pressure of any spot welding machine regardless of cylinder size or air pressure. This is better than reducing air pressure, which slows the return stroke and retards production.

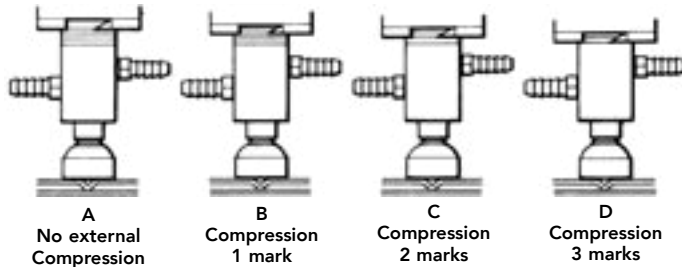

For every one-eighth of an inch that a fast follow-up is compressed when setting up, a known amount of force is provided, to quickly follow up any reduction in work thickness. Example: at position B, a type MH spring would delivery 310 lb, at C, 440 lb, etc.

## FAST FOLLOW-UP FORCE CHART (LBS.)

Spring Type	1/8-in. Compression	1/4-in. Compression	3/8-in. Compression	1/2-in. Compression
M (300 lbs. max.)	140	200	250	300
MH (680 lbs. max.)	310	440	560	680
H (1300 lbs. max.)	600	840	1070	1300

Mounting Style	300 LBS. MAX. (M SPRING)		680 LBS. MAX. (MH SPRING)		1300 LBS. MAX. (H SPRING)	
	Descr-ption	Part No.	Descr-ption	Part No.	Descr-ption	Part No.
1" Shank	4620	350-4620	4621	350-4621	4622	350-4622
1-1/4" Shank	4623	350-4623	4624	350-4624	4625	350-4625
1-1/2" Shank	4626	350-4626	4627	350-4627	4628	350-4628
Platen-Mtd.	4629	350-4629	4630	350-4630	4631	350-4631



**ULTRAPRESSURE™ FAST FOLLOW-UP HOLDER SYSTEM**

*U.S. Patent Pending*

TUFFALOY'S UltraPressure™ Fast Follow-Up Holder System is a low profile, spring loaded electrode holder designed specifically for new or existing resistance welding tooling that requires the additional follow-up force. Available in a range of forces from 750 to 10,000 lbs., utilizing easily replaceable dies springs to configure the holder to the weld application. These holders are especially effective for projection welding on AHSS, and in conjunction with Fast Rise Time (FRT) Transformers. UltraPressure body weighs 8.8 lbs.

ULTRAPRESSURE FAST FOLLOW-UP HOLDER SYSTEM				
ULTRAPRESSURE BODY			MOUNTING OPTIONS	
Part No.	Force at Compression (Lbs.)		Part No.	Description
	0.063"	0.125"		
350-4640	375	750	195-5680	5 RW Mount
350-4641	700	1250	195-7063	Cylinder Mount**
350-4642	1000	2000	195-7060	1.00" OD Shank Mount
350-4643	1500	2750	195-7061	1.25" OD Shank Mount
350-4644	1850	3500	195-7062	1.50" OD Shank Mount
350-4650	3250	6500	195-6146	Platen Mount
350-4652	5000	10000		**Fits Clamp 194-2040

*To specify the electrode mounting type, please add one of these suffix's to the holder body part number (-5RW, -6RW, -7RW, -.875 for 7/8-14 or -1.0 for 1-12).*

ULTRAPRESSURE BODY  
-SEE CHART FOR MOUNTING OPTIONS-

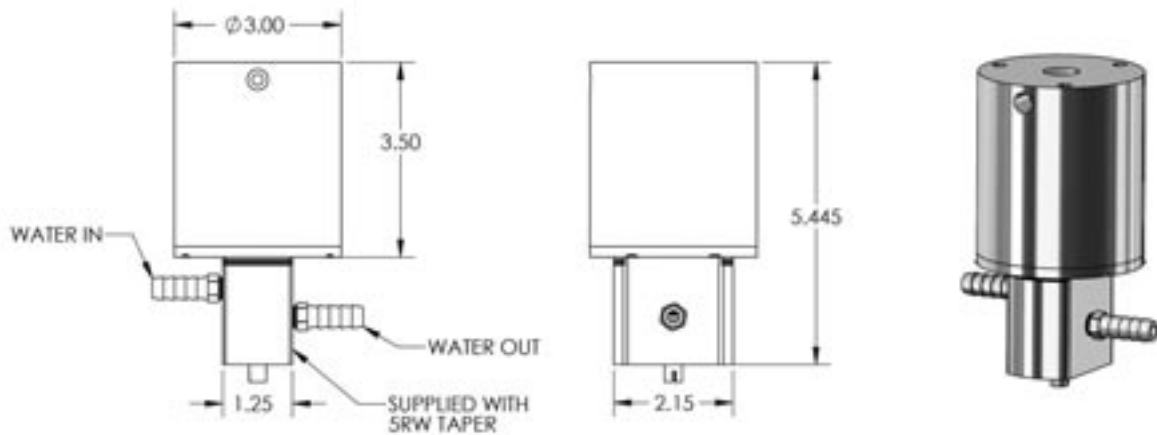

MOUNTING OPTIONS



# TUFFALOY BAR STOCK

TUFFALOY extruded bar stock is used for fabricating special electrodes, platens, adapters, and other conductive parts. Round bar is available in all three alloy classes (1, 2 & 3). The other shapes are made in Class 2 and 3 alloy. Physical properties are superior to those shown on page 54.

Bar stock is priced per pound in random mill lengths, from 8 to 12 feet. Additional charges are made depending on specific weights and lengths ordered.

	Size In Inches	Weight Pounds Per Foot	Tuffaloy 88 Class 1.15000 Alloy Item No.	Tuffaloy 77 Class 2.18200 Alloy Item No.	Tuffaloy 55 Class 3.17510 Alloy Item No.
<b>ROUND</b>	1/8	.048			431-0125
	3/16	.106		421-0187	431-0187
	1/4	.189		421-0250	431-0250
	5/16	.296		421-0313	431-0313
	3/8	.426		421-0375	431-0375
	1/2	.758		421-0500	431-0500
	9/16	.959		421-0562	431-0562
	5/8	1.184	411-0625	421-0622	431-0625
	21/32	1.82		421-0656	
	3/4	1.704	411-0750	421-0748	431-0750
	7/8	2.32	411-0875	421-0872	431-0875
	1	3.03		421-1000	431-1000
	1-1/8	3.84		421-1125	431-1125
	1-1/4	4.74		421-1250	431-1240
	1-3/8	5.74		421-1375	431-1375
	1-1/2	6.82		421-1500	431-1500
	1-5/8	7.97			431-1625
	1-3/4	9.28		421-1750	431-1750
2	12.12		421-2000	431-2000	
2-1/8	13.62			431-2125	
2-1/4	15.40		421-2250	431-2250	
2-1/2	18.97		421-2500	431-2500	
2-3/4	23.00		421-2750		
3	27.15		421-3000	431-3000	
3-1/4	32.05			431-3250	
3-1/2	37.18			431-3500	
<b>HEXAGONAL</b>	3/8	.472		422-0375	
	5/8	1.31		422-0625	
	3/4	2.18		422-0750	432-0750
	7/8	2.56		422-0875	432-0875
	1	3.35		422-1000	432-1000
	1-1/8	4.24		422-1125	432-1125
1-1/4	5.25		422-1250	432-1250	
1-1/2	7.55		422-1500	432-1500	
<b>SQUARE</b>	1/4	.24			433-0250
	3/8	.54			433-0375
	1/2	.96		423-0500	433-0500
	5/8	1.56		423-0625	433-0625
	3/4	2.16		423-0750	433-0750
	1	3.84		423-1000	433-1000
	1-1/4	6.00		423-1250	433-1250
	1-1/2	8.64		423-1500	433-1500
	1-3/4	11.83		423-1750	
	2	15.46		423-2000	433-2000

	Size In Inches	Weight Pounds Per Foot	Tuffaloy 77 Class 2.18200 Alloy Item No.	Tuffaloy 55 Class 3.17510 Alloy Item No.
<b>RECTANGULAR</b>	1/4 x 1/2	.484		434-0205
	1/4 x 3/4	.727		434-0207
	1/4 x 1	.96	424-0210	434-0210
	1/4 x 1-1/4	1.20	424-0212	
	1/4 x 1-1/2	1.44	424-0215	434-0215
	1/4 x 2	1.92	424-0220	434-0220
	3/8 x 5/8	.900		434-0306
	3/8 x 3/4	1.08	424-0307	434-0307
	3/8 x 1	1.44	424-0310	434-0310
	3/8 x 1-1/2	2.16	424-0315	
	3/8 x 2	2.88		434-0320
	1/2 x 3/4	1.44	424-0507	434-0507
	1/2 x 1	1.92	424-0510	434-0510
	1/2 x 1-1/4	2.40		434-0512
	1/2 x 1-1/2	2.138	424-0515	434-0515
	1/2 x 2	3.134	424-0520	434-0520
	1/2 x 2-1/2	4.133	424-0525	434-0525
	1/2 x 3	5.81	424-0530	434-0530
	5/8 x 3/4	1.80	424-0607	434-0607
	5/8 x 1	2.40	424-0610	434-0610
	5/8 x 1-1/2	3.60	424-0615	434-0615
	5/8 x 2	4.85	424-0620	434-0620
	5/8 x 3	7.27	424-0630	
	5/8 x 4	9.60	424-0640	
	3/4 x 1	2.88	424-0710	434-0710
	3/4 x 1-1/4	3.64	424-0712	434-0712
	3/4 x 1-1/2	4.32	424-0715	434-0715
	3/4 x 2	5.72	424-0720	434-0720
	3/4 x 2-1/4	6.48		434-0722
	3/4 x 2-1/2	7.20	424-0725	434-0725
3/4 x 3	8.64	424-0730		
1 x 1-1/4	4.85	424-1012	434-1012	
1 x 1-1/2	5.76	424-1015	434-1015	
1 x 2	7.68	424-1020	434-1020	
1 x 2-1/2	9.70	424-1025	434-1025	
1 X 2-3/4	10.56	424-1027		
1 X 3	11.55	424-1030	434-1030	
1-1/4 x 1-1/2	7.25	424-1215		
1-1/4 x 1-3/4	8.40	424-1217		
1-1/4 X 2	9.60	424-1220		
1-1/4 X 2-1/2	12.06	424-1225		
1-1/2 x 1-3/4	10.09	424-1517		
1-1/2 x 2	11.60	424-1520	434-1520	
1-1/2 x 3	17.28	424-1530	434-1530	
2 x 3-1/4	25.15	424-2032		
2 x 3-3/4	29.05	424-2037		



Stronger, generally harder, and having less conductivity, the refractory metal compositions include copper-tungsten (Classes 10-11), tungsten (Class 13) and molybdenum (Class 14) alloys.

The bars and inserts listed below are made in the following RWMA group B alloys: Class 10 (Tuffaloy 1W), Class 11 (Tuffaloy 10W), and Class 12 (Tuffaloy 20W).

Bars and inserts of Class 13 (Tuffaloy 100W) and Class 14 (Tuffaloy 100M), as well as special sizes and shapes, are priced on request.

### COPPER TUNGSTEN ROUND BARS

Eight inches long, available in the following diameters:

From 1/8" to 2".



### COPPER TUNGSTEN RECTANGULAR AND SQUARE BARS

Eight inches long, available in following dimensions:

Widths from 1/8" to 2" and Thicknesses from 1/8" to 1".



### COPPER TUNGSTEN ROUND INSERTS

Available in following dimensions:

Diameters from 1/8" to 2" and Thicknesses from 1/4" to 1".

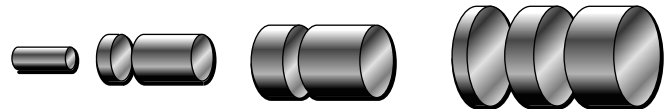

## TUFFALOY FORGINGS

TUFFALOY forgings are used to make seam welder wheels and shafts, butt and flash welder dies, and welder arms and platens. Forgings are superior to castings in physical properties and in absence of porosity. They are available in TUFFALOY 88, 77 and 55 (Class 1, 2 and 3 alloy). All are readily machinable.

When ordering specify whether forging is to be as-forged or finish machined. Regardless of how it is wanted always order by giving finish dimensions.

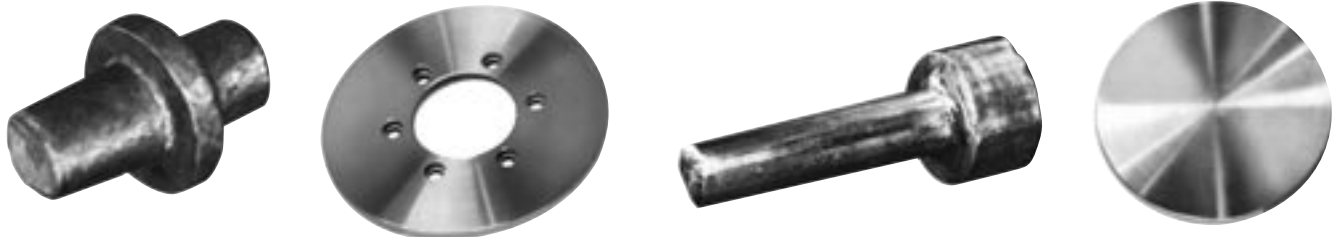

### SAFETY DATA SHEETS

[www.tuffaloy.com/technical/sds](http://www.tuffaloy.com/technical/sds)



# TUFFALOY SHUNTS AND JUMPERS

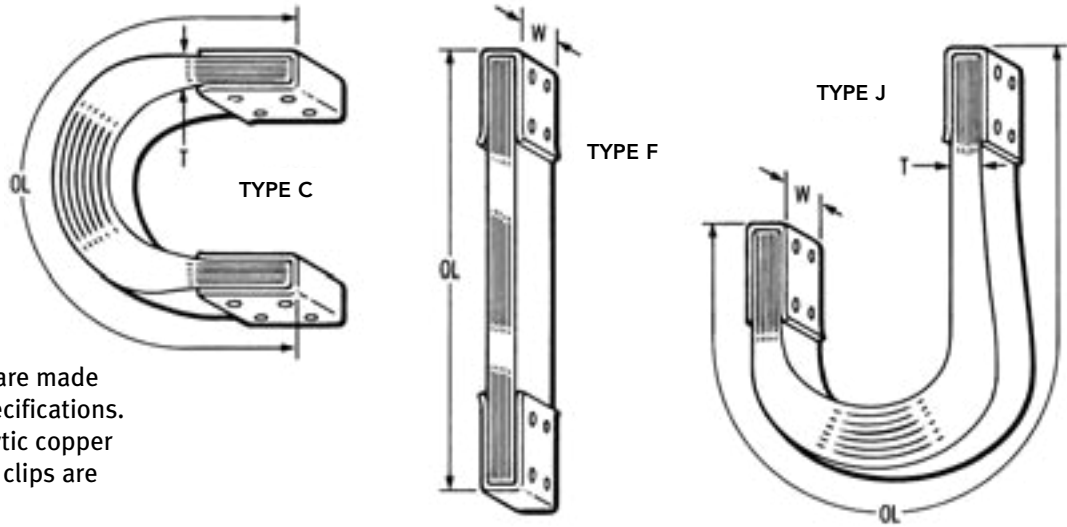

Laminated copper shunts are made to your size and shape specifications. High conductivity electrolytic copper strip is used, and terminal clips are riveted in place.

## HOW TO ORDER

Give the following information:

Type (C, F, or J)

Outside length (OL)

Width (W)

Thickness (less clip) (T)

Hole pattern (specify by letter code)

Hole location (X, Y, Z values)

Hole diameter

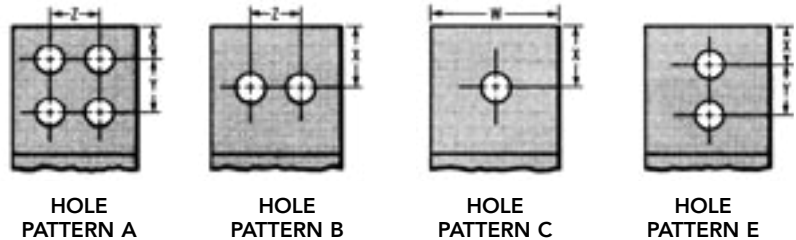

Air-cooled jumper cables are flexible, high-conductivity copper conductors with insulative sleeves. They are made in lengths to suit your needs.

## HOW TO ORDER

Give the following information:

Conductor rating (MCM)

Length between holes

Terminal orientation style

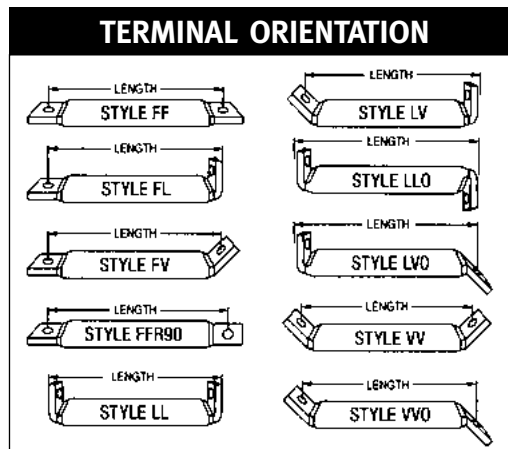

DIMENSIONS, INCHES			
MCM Rating	O.D. (approx.)	Lug Width A	Lug Thickness B
600	1-5/8	1-3/8	.50
750	1-3/4	1-3/8	.60
1000	2	1-1/2	.70
1200	2-1/8	1-1/2	.82
1500	2-1/4	1-1/2	.99

Holes are 17/32 unless otherwise specified.

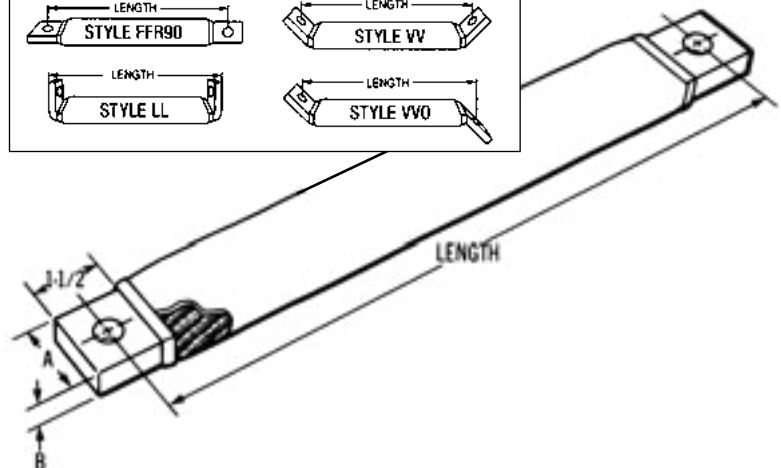



**ELECTRODE TAPER REAMERS & TAP**



Hole in reamer center permits water tube entry; no need to dismantle holder. 4 RW; Part No. 601-0004; 5 RW, Part No. 601-0005; 6 RW, Part No. 601-0006; 7 RW, Part No. 601-0007. 5/8-14 NPT Tap, Part No. 601-0025

**TIP DRESSING TOOL**



To remove mushroomed nose material on a pair of tips of 4 or 5 RW size, having pointed or dome noses. Other nose design dressers on special order. Dresser, Part No. 601-0102; Dresser cutter, Part No. 601-0103.

**RADIUS TIP FILE**



Tip File

To restore original contours of welding tips use this two-inch radius file. File, Part No. 601-0120; Handle, Part No. 601-0120-H; File & Handle, Part No. 601-0120-A.

**WELDING TIP EXTRACTORS**



No. 4 RW and 5 RW at opposite ends, EX-3, Part No. 601-0203



No. 4 RW, EX-1, Part No. 601-0201  
No. 5 RW, EX-2, Part No. 601-0202



Standard Duty: EX-10-A, Part No. 601-0231  
Heavy Duty: SW-250, Part No. 601-SW-250

**TUFFCAP EXTRACTORS**

Male Caps, 4 & 5 RW, EX-45, Part No. 601-0240  
Male Caps, 5 & 6 RW, EX-56, Part No. 601-0242

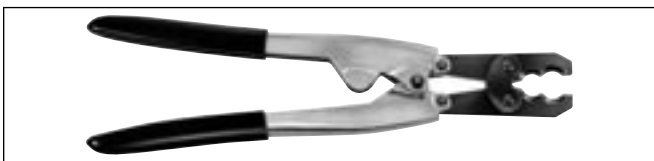

Male cap extractor has long lever handles for easier cap removal. In two dual-size models: EX-45 and EX-56.

**TUFFCAP ELECTRODE REAMERS**

To ream or dress tapers to hold male caps. 4 RW, Part No. 601-0014; 5 RW, Part No. 601-0015; 6 RW, Part No. 601-0016.

**QUICK-CONNECT COUPLINGS with automatic shut-off**

Use these couplings to make up efficient, trouble free coolant systems. Any plug shown will mate with any socket shown. Always put the socket on the upstream side of a connection. Its built-in valve will automatically close upon disconnection.



1/8" NPT female plug  
Part No. 601-0300



1/8" NPT female socket  
Part No. 601-0314



1/8" NPT male plug  
Part No. 601-0301

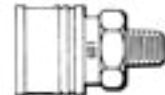

1/8" NPT male socket  
Part No. 601-0315



1/4" NPT male plug  
Part No. 601-0302

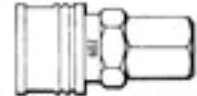

1/4" NPT female socket  
Part No. 601-0316



1/4" NPT male plug  
Part No. 601-0303



1/4" NPT male socket  
Part No. 601-0317



3/8" ID hose plug  
Part No. 601-0309



3/8" ID hose socket  
Part No. 601-0320

**CONDUCTIVE LUBE**

Part No. 601-0400  
1 lb. container

**WATER HOSE**

Part No. 601-0350  
3/8 ID

**HOSE CLAMP**

Part No. 601-0340

**HOSE BARB**

1/8-NPT Part No. 195-8240  
1/4-NPT Part No. 195-8241

Female Caps, 4 RW, EX-4F, Part No. 601-0220 Male Cap 4 RW  
Female Caps, 5 RW, EX-5F, Part No. 601-0221 Male Cap 5 & 6 RW  
Female Caps, 6 RW, EX-6F, Part No. 601-0222 Male Cap 7 RW

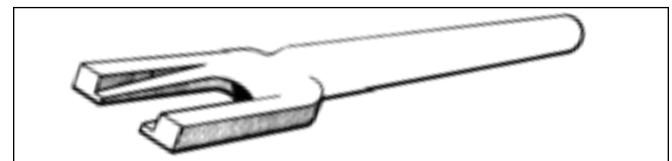

Female cap extractors are made for three Tuffcap shank sizes: Models EX-4F, EX-5F, and EX-6F.



## WA2 WELD ANALYZER

- Current meter
- Easy to use
- Easily legible in all lighting conditions
- Positive keypad action
- Suitable for various applications
- Reads wave forms from 50 Hz upwards
- Traceable accuracy
- Data archiving
- Small and lightweight allowing for easy portability
- Calibration services available
- One year warranty



### FEATURES

- Intuitive, flexible interface
- LCD 128 x 64 pixels FSTN with yellow/green backlight
- Embossed disc tactile keypad with antiglare display window
- Auto power-off
- Large choice of coils
- AC or MFDC operation
- Calibration certification
- USB connection
- Includes 6 inch flexible coil, batteries and carrying case
- Integrator output for oscilloscope connection
- WA Terminal software

### OPTIONS

- Flexible coil – 3 inch (Part No. 313027) or 12 inch (Part No. 313021) diameter with 6.5 feet lead
- Attenuator – range multiplier for up to 300kA (Part No. 316009)
- Extension cable – 10 meters (Part No. 316010)



### WA2 WELD ANALYZER VIDEO

<https://youtu.be/A2QcopGG5AM>



**WA2 WELD ANALYZER SPECIFICATIONS**

The Weld Analyzer offers the engineering professional the facilities to analyze, fault-find and improve process quality on today's sophisticated welding control systems. Full traceability gives you the confidence in your processes that your customers demand.



**POWER SOURCE:** Rechargeable NiMH  
**DISPLAY:** 128 x 64 pixels FSTN transfective with yellow/green backlight  
**CURRENT RANGE:** 2.00 to 60.00 kA  
**CURRENT DURATION:** 9999 cycles (AC), 199.9 seconds (DC)

**MONITORED PARAMETERS:**

Current	Time	Conduction Angle	Position
Peak RMS	Total weld time	Average conduction angle	Position of monitored parameter in weld pulse train
Average RMS	Any pulse time	Conduction angle of every sample	
Lowest RMS	Number of pulses	Accuracy ± 4°	
Accuracy +/- 2% of full scale	Accuracy +/- 0		
Measures and displays values for each + and - 1/2 cycle			

**PROGRAMMABLE PARAMETERS:**

AC	DC
Frequency	Current threshold
Blanking	Blanking
Weld capture	Weld capture

**USB DRIVERS:** [www.ftdichip.com/Drivers/VCP.htm](http://www.ftdichip.com/Drivers/VCP.htm)

**DIMENSIONS:** 3-3/80 w x 1-1/80 d x 6-3/40 h; 1 lb. including batteries

**DISPLAY EXAMPLES:**

	AC	DC
<b>Display</b>		
<b>Data</b>		
<b>Detail</b>		
<b>Setup</b>		



**HIGH-ACCURACY WELD FORCE GAUGES AVAILABLE FROM TUFFALOY**

Digital-Electronic Weld Probe



DLC Digital-Electronic

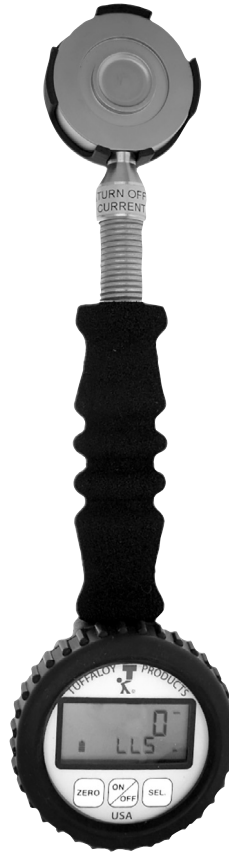

Analog-Hydraulic



**DLC Gauge Insulation Boot**  
Part No. 601-1006



**Hydraulic Gauge Insulation Boot**  
Part No. 601-1104

*Note: only compatible with swivel head style hydraulic gauges*



**THE BROADEST PRODUCT LINE OF FORCE GAUGES FOR RESISTANCE WELDING**

Tuffaloy supplies a range of weld force gauges, available with accuracies from  $\pm 0.5\%$  for Digital-Electronic gauges; to our Analog-Hydraulic models with 2%-3% accuracy. All are available in English and metric readouts.

Our **Digital-Electronic Weld Probe** weld through force gauge offers the highest accuracy of  $\pm 0.5\%$  for 95% of the gauges range. The gauge has large LCD readouts with peak-hold capabilities. All functions are electronic which prevents variations caused by flexing.

The **DLC Digital-Electronic** force gauge delivers better accuracy than hydraulic gauges, over a broader range of forces, due to the advanced digital load cell. Users can easily select their preferred units of measure in pounds, kilograms, newtons and kilonewtons. The peak-hold feature allows for reading variable forces, which are common in resistance welding machinery. Gauges maintain an accuracy of  $\pm 0.5\%$  for 30% to 90% of the gauge's range.



Tuffaloy's **Analog-Hydraulic** force gauges are the low cost method for obtaining general force measurements. These gauges are available in a standard block style, with sizes ranging from 600 to 10,000 pound maximum load, with accuracy of 2% at the mean and 3% outside of mean for 70% of the gauge's range.

**CERTIFICATE OF CALIBRATION, RECERTIFICATION AND REPAIR SERVICES**

All gauges are sold with an NIST traceable calibration, performed by Tuffaloy in house at time of sale. Units in the field may be sent in for recalibration and recertification. If the unit is not in good working order Tuffaloy can repair the unit prior to calibration and certification. If repaired by Tuffaloy there is no additional cost for calibration and certification.



STANDARD GAUGE DATA

Description	Features	Maximum Reading	Increment Every	Opening Required	Extension Length	Item Number	
<b>Digital-Electronic Weld Probe</b> 	<ul style="list-style-type: none"> <li>• Analog output</li> <li>• Auto shut-off</li> </ul>	0-1000 Lbs (Lbs/Kg)	1 Lb	1/4"	10"	601-8010MD-A	
		0-454 Kg (Kg/KN)	1 Kg	1/4"	10"	601-8010MD-B	
	<ul style="list-style-type: none"> <li>• No-weld setting-not required</li> </ul>	0-4.45 KN (KN/Lbs)	0.01 KN	1/4"	10"	601-8010MD-C	
		0-3000 Lbs (Lbs/Kg)	10 Lb	1/2"	10"	601-8030MD-A	
	<ul style="list-style-type: none"> <li>• Accuracy 0.50% over full range</li> </ul>	0-1360 Kg (Kg/KN)	10 Kg	1/2"	10"	601-8030MD-B	
		0-13.30 KN (KN/Lbs)	0.1 KN	1/2"	10"	601-8030MD-C	
		0-5000 Lbs (Lbs/Kg)	10 Lb	1.1"	10"	601-8050MD-A	
		0-2270 Kg (Kg/KN)	10 Kg	1.1"	10"	601-8050MD-B	
		0-22.24 KN (KN/Lbs)	0.1 KN	1.1"	10"	601-8050MD-C	
		0-10000 Lbs (Lbs/Kg)	10 Lb	1.1"	10"	601-8100MD-A	
		0-4540 Kg (Kg/KN)	10 Kg	1.1"	10"	601-8100MD-B	
		0-44.48 KN (KN/Lbs)	0.1 KN	1.1"	10"	601-8100MD-C	
Description	Features	Maximum Reading	Increment Every	Opening Required	Over All Length	Item Number	
<b>DLC Digital-Electronic</b> 	<ul style="list-style-type: none"> <li>• Accuracy 0.50%</li> <li>• NIST traceable certification</li> <li>• Response time less than 500 ms</li> <li>• Field selectable units switch between: Pounds Kilograms Newtons Kilonewtons</li> <li>• Peak hold feature</li> </ul>	3000 Lb	1 Lb	9/16"	13"	601-3000DLC	
		1363 Kg	1 Kg	9/16"	13"		
		13344 N	1 N				
		13.34 KN	0.01 KN	9/16"	13"		
		5000 Lb	1 Lb			9/16"	13"
		2272 Kg	1 Kg				
		2224 N	1 N	9/16"	13"		
		22.24 KN	0.01 KN				
		10000 Lb	1 Lb			9/16"	13"
4544 Kg	1 Kg						
4448 N	1 N						
		44.48 KN	0.01 KN	9/16"	13"		
Description	Features	Maximum Reading	Increment Every	Opening Required	Over All Length	Item Number	
<b>Analog-Hydraulic*</b> 	<ul style="list-style-type: none"> <li>• Accuracy 3%</li> <li>• Pivoting head</li> </ul>	0-600 Lbs	10 Lb	3/4"	6"	601-8006	
		0-2000 Lbs	50 Lb	3/4"	6"	601-8020	
		0-3000 Lbs	20 Lb	3/4"	6"	601-8030	
		0-5000 Lbs	100 Lb	3/4"	8"	601-5000	
		0-10000 Lbs	100 Lb	3/4"	8"	601-8100	
		0-5000 Kg	50 Kg	3/4"	8"	601-8101	

\*Hydraulic gauges should be selected to be used near mid-range.





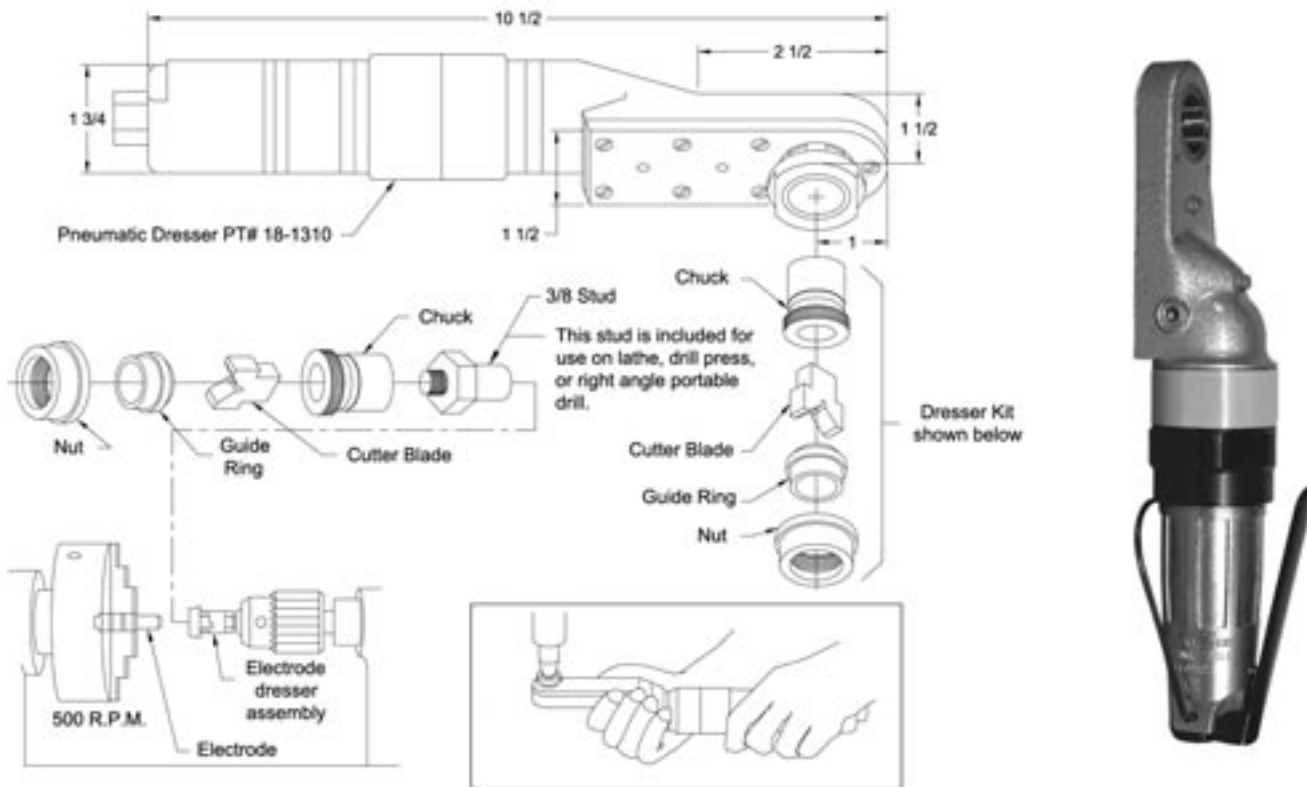





## PNEUMATIC POWER HANDLE ELECTRODE DRESSER PART NO. 18-1310

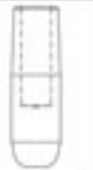

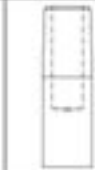
Light weight and rugged construction, this Pneumatic Power Handle requires a clearance of only 1-1/2" with a standard ring and 2" with an extended ring. In most situations this allows dressing of electrodes without removal from the welder. Operating at a cutting speed of 1200 rpm, it enables the operator to dress electrodes quickly and accurately. Cutters and guide rings are easily replaced. These must be matched to the electrode nose and are selected from the chart below.

**Electrode Dresser 18-1310 is supplied without blade holder, ring, and cutter blade.** When ordering, specify the "Kit" appropriate for your dressing needs as selected from the table below. "The stud" furnished with the kit is not required when using the Pneumatic Power Handle. It may optionally be used, but will increase the clearance required on the welder for dressing. Additional special cutters can be furnished upon special request.

These kits may also be used for cap electrode dressing.

Size To Dress									
4 RW .482 Dia	Nose style	Dome	Pointed	Flat	2" Radius	3" Radius	4" Radius	10" Radius	Truncated
	Kit to Order**	18-1390411	18-1390420	18-1390410	18-1390413	18-1390414	18-1390415	18-1390416	18-1390412
	Replacement Blade	18-139411	18-139420	18-139410	18-139413	18-139414	18-139415	18-139416	18-139412
	Replacement Guide Ring (Each for above kit)	18-139401	18-139402	18-139401	18-139401	18-139401	18-139401	18-139401	18-139401
5 RW .625 Dia	Kit to Order**	18-1390511	18-1390520	18-1390510	18-1390513	18-1390514	18-1390515	18-1390516	18-1390512
	Replacement Blade	18-139511	18-139520	18-139510	18-139513	18-139514	18-139515	18-139516	18-139512
	Replacement Guide Ring (Each for above kit)	18-139501	18-139502	18-139501	18-139501	18-139501	18-139501	18-139501	18-139501

\*\* Note: This kit includes Stud for (for 3/8 Keyed Chuck), Chuck, 1 Guide Ring, 1 Appropriate blade, and Retaining Nut.

Note: Cutters are **NOT** designed to conform to "Electrode Cap" geometries. Caps are intended for value salvage when expended.



## RECOMMENDED USES OF RESISTANCE WELDING MATERIALS

### GROUP A COPPER-BASE ALLOYS

#### RWMA CLASS 1 ALLOY • TUFFALOY 88

ZIRCONIUM-COPPER (1.15000), is suited to welding aluminum and magnesium alloys, coated materials, brass and bronze.

Class 1 alloy is superior to pure copper as an electrode material and is recommended as a general purpose material for resistance welding use. It may be used for spot welding electrodes, seam welding wheels and welding fixture components. It is not heat treatable.

#### RWMA CLASS 2 ALLOY • TUFFALOY 77 AND Z

TUFFALOY 77 CHROMIUM-COPPER (2.18200), is suited to welding cold- and hot-rolled steels, stainless steel, and low-conductivity brasses and bronzes.

Class 2 alloy is a superior resistance welding electrode material, recommended for high-production operations. It is used for welding electrodes, projection welding electrodes, seam welding shafts and bearings, flash and butt welding electrodes, and current-carrying structural components. Available in forms for use as welding gun arms, welding platens and secondary-circuit structural members. It is heat treatable.

TUFFALOY Z ZIRCONIUM-CHROMIUM-COPPER (2.18150), is suited to welding galvanized steel and other metallic-coated steel.

This is a specially heat-treated alloy which meets the minimum electrical conductivity and hardness specifications of Class 2 alloy.

#### RWMA CLASS 3 ALLOY • TUFFALOY 55 AND 55A

TUFFALOY 55 BERYLLIUM-NICKEL-COPPER (3.17510), is suited to welding steels having high electrical resistance, such as stainless steel.

TUFFALOY 55A NICKEL-COPPER (3.18000), is a beryllium-free alloy with properties similar to TUFFALOY 55.

Class 3 alloy is recommended for projection welding electrodes, and flash and butt welding electrodes. With its higher strength it is also used on highly-stressed current-carrying parts such as electrode shanks and heavy-duty electrode holders. It is heat treatable.

#### RWMA CLASS 4 ALLOY • TUFFALOY 44

BERYLLIUM-COPPER (4.17200) has extremely high hardness, and is recommended for projection, flash and butt welding electrodes. It has lower conductivity than Class 3 alloy but it is harder and more wear resistant. It should be considered where there is concern with high pressure density and severe wear, but where heating, due to its low conductivity, is not excessive.

It is used frequently in the form of inserts, tooling facings, and seam welder bushings. It is available in the annealed condition which is more readily machined and then subsequently heat treated.

### GROUP B REFRACTORY METAL COMPOSITIONS

#### RWMA CLASS 10 • TUFFALOY 1W

TUNGSTEN 55% – COPPER 45%, suited for facings and inserts for projection welding electrodes and flash and butt welding electrodes. It is recommended where (relatively) high electrical conductivity and some degree of malleability is desired.

#### RWMA CLASS 11 • TUFFALOY 10W

TUNGSTEN 75% – COPPER 25%, suited to similar applications as Class 10, and for facing on electrode forming electrodes. It is harder than Class 10, and is for general use in projection welding electrodes.

#### RWMA CLASS 12 • TUFFALOY 20W

TUNGSTEN 80% – COPPER 20%, suited for electro-forming and electro-forging facings, and for electrode facings used to upset studs and rivets. A material for heavy-duty projection welding electrodes.

#### RWMA CLASS 13 • TUFFALOY 100W (Pure Tungsten)

#### RWMA CLASS 14 • TUFFALOY 100M (Pure Molybdenum)

Class 13 & 14 materials are used primarily for welding or electro-brazing non-ferrous metals having relatively high electrical conductivity. They are suited to cross-wire welding of copper and brass, and for welding copper wire braid to brass or bronze terminals. Special set-ups and procedures are required.

#### SAFETY DATA SHEETS

[www.tuffaloy.com/technical/sds](http://www.tuffaloy.com/technical/sds)



**MINIMUM PHYSICAL PROPERTIES FOR RWMA ALLOYS**

**Published Standards of the Resistance Welder Manufacturer's Association**

		Class	TUFFALOY Number	Proportional Limit Tension P. S. I.	Hardness Rockwell	Conductivity Percent I. A. C. S.	Ultimate Tensile Strength P. S. I.	Elongation Percent In 2' or 4' Diameter
<b>GROUP A</b> Copper Base Alloys	ROUND RODS Up to 1" dia.	1	88	17,500	65-B	80	60,000	13
		2	77	35,000	75-B	75	65,000	13
		3	55	50,000	90-B	45	100,000	9
	1" to 2" dia.	1	88	15,000	60-B	80	55,000	14
		2	77	30,000	70-B	75	59,000	13
		3	55	50,000	90-B	45	100,000	9
	2" to 3" dia.	1	88	15,000	55-B	80	50,000	15
		2	77	25,000	65-8	75	55,000	13
		3	55	50,000	90-B	45	95,000	9
	BARS Square Rectangular Hexagon Up to 1" thick	1	88	20,000	55-B	80	60,000	13
		2	77	35,000	70-B	75	65,000	13
		3	55	50,000	90-B	45	100,000	9
	Over 1" thick	1	88	15,000	50-B	80	50,000	14
		2	77	25,000	65-8	75	55,000	13
		3	55	50,000	90-B	45	100,000	9
	FORGINGS Up to 1"	1	88	20,000	55-8	80	45,000	12
		2	77	22,000	65-B	75	55,000	13
		3	55	50,000	90-B	45	94,000	9
1" to 2"	1	88	15,000	50-B	80	40,000	13	
	2	77	21,000	65-B	75	55,000	13	
	3	55	50,000	90-B	45	94,000	9	
Over 2"	1	88	15,000	50-B	80	40,000	-	
	2	77	20,000	65-B	75	55,000	12	
	3	55	50,000	90-B	45	94,000	5	
All sizes	4	44	85,000	33-C	20	140,000	.5	
CASTINGS All sizes	2	77	20,000	55-8	70	45,000	12	
	3	55	45,000	90-B	45	85,000	5	
	4	44	60,000	33-C	18	90,000	.5	
	5	66	12 to 16,000	65 to 85-B	10 to 15	65 to 75,000	2 to 10	
<b>GROUP B</b> Refractory Metal Compositions	Rods, Bars & Inserts	10	1W		72-B	35	135,000 160,000 170,000 200,000	Ultimate Compression Strength P. S. I.
		11	10W		94-B	28		
		12	20W		98-B	27		
		13	100W		69-A	30		
		14	100M		85-B	30		





# RECOMMENDED ELECTRODE MATERIALS

	Tungsten Molybdenum	Mag nesium	Nickel Alloys	Nickel	Stainless Steel	Chrome Steel	Cadmium Plate	Galvanized Steel Zn. Plate	Terne Plate	Tin Plate	Scaly Steel	C.R. Steel	Phos- phor Bronze	Silicon Bronze	Nickel Silver	Cupro Nickel	Brass Yellow	Brass Red	Copper	Aluminum Alloys	Aluminum	C.P. Titanium	
Commercially Pure Titanium																							A <sup>1</sup> <sub>10</sub> B <sup>1</sup> <sub>10</sub>
Aluminum 2S-3S			C I E II E II H I H II E I D I D I D I									E II D II D II						D II E II H V C I C I					
Aluminum Alloys Duralumin 52S-17S-24S			C I E II E II H I H II E I D I D I D I									E II D II D II						D II E II E V D I					
Copper - Pure			H II H I E II E II H I H II H I H I H I									H II D II D II D II D II D II E II K V											
Brass - Red 5-25% Zinc			H I D V D II H II H II H I H I H I									H II D II D II D II D II D II E II											
Brass - Yellow 23-40% Zinc			E I D V D II H II H II H I H I H I									E II C II C II C II C II C II											
Cupro-Nickel			D I C II C VI E II E II E I E I E I H I E II C II C II B II																				
Nickel-Silver			D I C II C VI E II E II E I E I E I H I E II C II C II B II																				
Silicon Bronze			D I C II D II E II E II E I E I E I H I D II C II B II																				
Phosphor Bronze Grades A, C, & D			E I D V D II E II E II E I E I E I H I D II B II																				
C. R. Steel H. R. Steel - Clean			D II	D II D II B II B II C II C I B I C I E I A II																			
Scaly H. R. Steel			H II	D II D II D II D II D II D II E I E I																			
Tin Plate			E II E I D I D I C II C II D I C I D I D I																				
Terne Plate			E II E I D I D I C II C II C I C I C I																				
Galvanized Steel Zinc Plate			E II E I D I D I C II C II C I C I C I																				
Cadmium Plate			E II E I D I D I C II C II C I																				
Chrome Plate			D II	D II D II B II B II																			
Stainless Steel 18-8 Type			D II	D II D II A II																			
Nickel Grade A			D II	C II B II																			
Nickel Alloys Monel Nichrome (High Res.)			D II	B II																			
Magnesium Alloys			D I																				
Molybdenum Tungsten			D II																				

**ELECTRODES**  
 I - RWMA CLASS 1  
 II - RWMA CLASS 2  
 III - RWMA CLASS 3  
 IV - RWMA CLASS 11 - 10W  
 V - RWMA CLASS 14 - 100M  
 VI - RWMA CLASS 10 - 1W Δ  
 \*100W may be substituted.  
 Δ = RWMA CLASS 11 may be interchanged.  
 O = Electrode materials in circles are second choice.

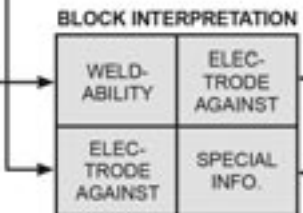

**WELDABILITY**  
 As a basis for comparison cold rolled (mild) steel has been chosen and its weldability designated as "excellent."  
 A - Excellent E - Poor  
 B - Very Good H - Very Poor  
 C - Good K - Impractical  
 D - Fair

- SPECIAL INFORMATION**
1. Good weld strength.
  2. May be welded under special conditions.
  3. Low weld strength.
  4. No actual weld nugget occurs, a "stick" is obtained.
  5. Welding conditions must be accurately controlled.
  6. Keep electrode clean to prevent sticking to the work.
  7. Good practice recommends cleaning steel before welding.
  8. Use one flat tip to minimize distortion or discoloration.
  9. Coating may dissolve in other metals or burn away.

The process of resistance welding makes it possible to join most metals, similar or dissimilar. Bonds of adequate strength are obtainable for an extremely wide range of applications. Selecting electrodes of the proper alloy is a most important consideration in producing good welds at the required speed. The chart below is a valuable guide to this selection.

The weldability of two materials as expressed in the following chart has been derived after careful laboratory study and field survey of many factors which influence the welding or resultant weld of the metals. The factors include:

1. Thermal and electrical conductivity
2. Metallurgical properties
3. Nature of resultant weld or alloy
4. Weld strength
5. Relative accuracy in control of welding conditions necessary

The weldability of metals as shown in the chart applies only when conventional spot welding methods are used on similar thicknesses of material. However, many metal combinations which are listed as having a "poor weldability" may be satisfactorily joined by using a special setup or procedure.

There is a TUFFALOY Alloy for each specific welding application. Experienced TUFFALOY engineers will provide assistance with special problems.



This Chart shows graphically the importance of Electrode maintenance. This is not only important from the quality of the weld, which is of first importance, also extra load added to the welding machine and equipment. Read the data on the chart, you can then draw your own conclusions.

## YOU CAN'T AFFORD TO NEGLECT YOUR ELECTRODES!

Keep your Electrodes dressed for maximum production and quality welds.

## A TIP DRESSER WILL PAY DIVIDENDS!

We can supply you with hand operated Tip Dressers or Pneumatic Power Driven Dressers. Design or type will depend on your production requirements. Pages 45 & 50.

## RESISTANCE WELDING

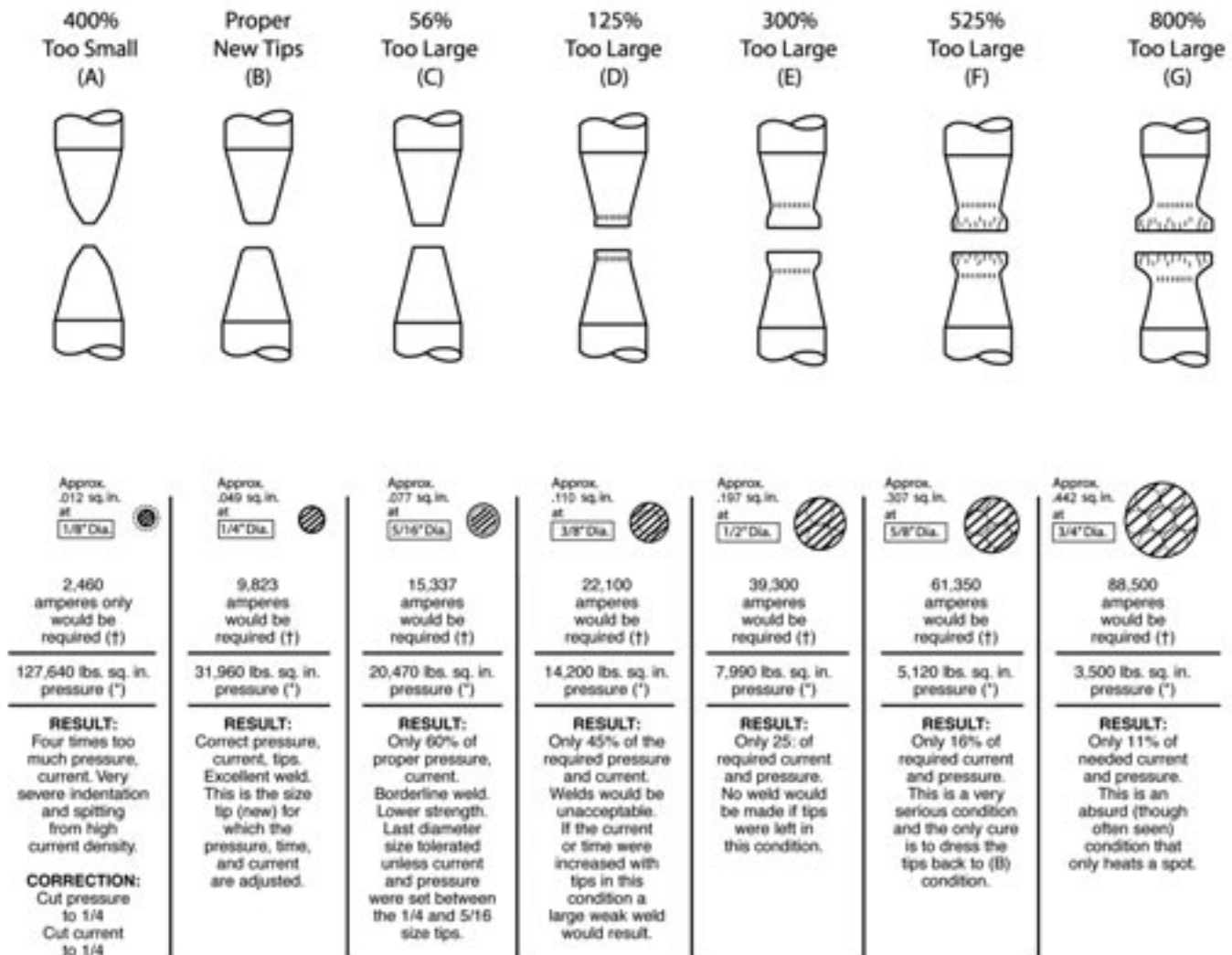

(†) Current density required for this gage to be 200,000 amps per sq. in. Setting is 9,900 amps for condition (B)

(\*) Five inch diameter air cylinder A 80 lbs. air pressure—1570 lbs. on ram.



Reproduced by permission of McGraw-Hill Book Company, Inc.



SPOT WELDING DATA

OPTIMUM CONDITIONS

SCHEDULES FOR SPOT WELDING LOW CARBON STEEL—SAE 1010

Thickness of Thinnest Outside Piece (Inches)	Electrode Diameters and Shape*			Recommended Minimum Standard Electrode Size	Weld Force (Lbs.)	Weld Time (Cycles) (60 Cycles per Sec.)	Hold Time (Cycles) Min.	Welding Current (Amps.) (Approx.)	Weld Shear Strength (For Steels Having Ultimate Tensile Strength of 90,000 psi and below) Minimum Strength (Lbs/Weld)	Diameter of Fused Zone (Approx.) 	Minimum Weld Spacing 	Minimum Contacting Overlap 
	Flat Face		Radius Face									
	Maximum d (Inches)	Min. D (Inches)	Radius R (Inches)									
0.010	0.125	1/2	2	4RW 1MT	160	4	5	4,000	130	0.113	1/4	3/8
0.021	0.187	1/2	2	4RW 1MT	244	6	8	6,500	300	0.139	3/8	7/16
0.031	0.187	1/2	2	4RW 1MT	326	8	10	8,000	530	0.161	1/2	7/16
0.040	0.250	5/8	3	5RW 2MT	412	10	12	8,800	812	0.181	3/4	1/2
0.050	0.250	5/8	3	5RW 2MT	554	14	16	9,600	1,195	0.210	7/8	9/16
0.062	0.250	5/8	3	5RW 2MT	670	18	20	10,600	1,717	0.231	1	5/8
0.078	0.312	5/8	3	5RW 2MT	903	25	30	11,800	2,365	0.268	1-1/8	11/16
0.094	0.312	5/8	4	7RW 3MT	1,160	34	35	13,000	3,054	0.304	1-1/4	3/4
0.109	0.375	7/8	4	7RW 3MT	1,440	45	40	14,200	3,672	0.338	1-5/16	13/16
0.125	0.375	7/8	4	7RW 3MT	1,760	60	45	15,600	4,300	0.375	1-1/2	7/8
0.156	0.500	7/8	6	Male or Female Threaded	2,500	93	50	18,000	6,500	0.446	1-3/4	1
0.187	0.625	1	6	Male or Female Threaded	3,340	130	55	20,500	9,000	0.516	2	1-1/2
0.250	0.750	1-1/4	6	Male or Female Threaded	5,560	230	60	26,000	18,000	0.660	4	1-1/2

PERMISSIBLE SCHEDULE VARIATIONS FOR SPOT WELDING LOW CARBON STEEL

Low Carbon Steel Spot Welding Data Chart—Single Impulse Welding

DATA COMMON TO ALL CLASSES OF SPOT WELDS				WELDING SET-UP FOR BEST QUALITY—CLASS A WELDS					WELDING SET-UP FOR MEDIUM QUALITY—CLASS B WELDS					WELDING SET-UP FOR GOOD QUALITY—CLASS C WELDS					
Thickness of Each of Two Pieces (Inches)	Electrode Diam. & Shape		Min. Weld Spacing (Note 4) Inches	Min. Contacting Overlap (Note 6) Inches	Weld Time (Note 7) Cycles	Electrode Force Pounds	Welding Current Amps.	Diam. of Fused Zone 	Average Tensile Shear Strength ±14% Pounds	Weld Time (Note 7) Cycles	Electrode Force Pounds	Welding Current Amps.	Diam. of Fused Zone 	Average Tensile Shear Strength ±17% Pounds	Weld Time (Note 7) Cycles	Electrode Force Pounds	Welding Current Amps.	Diam. of Fused Zone 	Average Tensile Shear Strength ±20% Pounds
	Min. D Inches	Max. d Inches																	
.010	1/2	1/8	1/4	3/8	4	200	4500	.13	235	5	130	3700	.12	200	15	65	3000	.11	160
.021	1/2	3/16	3/8	7/16	6	300	6100	.17	530	10	200	5100	.16	460	22	100	3800	.14	390
.031	1/2	3/16	1/2	7/16	8	400	8000	.21	960	15	275	6300	.20	850	29	135	4700	.18	790
.040	5/8	1/4	3/4	1/2	10	500	9200	.23	1305	21	360	7500	.22	1230	38	180	5600	.21	1180
.050	5/8	1/4	7/8	9/16	12	650	10300	.25	1820	24	410	8000	.23	1700	42	205	6100	.22	1600
.062	5/8	1/4	1	5/8	14	800	11600	.27	2350	29	500	9000	.26	2150	48	250	6800	.25	2050
.078	5/8	5/16	1-1/8	11/16	21	1100	13300	.31	3225	36	650	10400	.30	3025	58	325	7900	.28	2900
.094	5/8	5/16	1-1/4	3/4	25	1300	14700	.34	4100	44	790	11400	.33	3900	66	390	8800	.31	3750
.109	7/8	3/8	1-5/16	13/16	29	1600	16100	.37	5300	50	960	12200	.36	5050	72	480	9500	.35	4850
.125	7/8	3/8	1-1/2	7/8	30	1800	17500	.40	6900	60	1140	12900	.39	6500	78	570	10000	.37	6150

NOTES:

- Low Carbon Steel as hot rolled, pickled, and slightly oiled with an ultimate strength of 42,000 to 45,000 PSI Similar to SAE 1005—SAE 1010.
- Electrode Material is RWMA Class 2.
- Surface of steel is lightly oiled but free from grease, scale or dirt.
- Minimum weld spacing is that distance for which no increase in welding current is necessary to compensate for the shunted current effect in adjacent welds.

- Radius Face electrodes may be used:  
0.010 to 0.031 — 2" Radius  
0.031 to 0.078 — 3" Radius  
0.078 to 0.125 — 4" Radius



- Weld time is indicated in cycles of 60 cycle frequency.

- Tensile shear strength values are based on recommended test sample sizes:

Direction of Force	Thickness	Width	Length
	.000" to .025"	5/8"	3"
	.030" to .058"	1"	4"
	.059" to .115"	1-1/2"	5"
	.116" to .190"	2"	6"

- Tolerance for machining of electrode diameter "d" is ±.015" of specified dimension.

- Electrode force does not provide for force to press ill-fitting parts together.



## Spot welding galvanized low-carbon steel

Material Thickness notes 1, 2, & 3	Electrode Diameter And Shape note 4			Net Electrode Force Lb.	Welding Current (Approx.) Amps.	Weld Time Cycles	Weld Nugget Size In.	Minimum Tension-Shear Strength Lb.	Minimum Weld Spacing Inches	Minimum Contacting Overlap Inches
	D	d	Oc							
Inches	In.	In.	Deg.							
0.022	5/8	3/16	120	300	13000	8	0.15	550	5/8	5/8
0.030	5/8	3/16	120	400	13000	10	0.16	1000	5/8	5/8
0.036	5/8	1/4	120	500	13500	12	0.19	1180	3/4	5/8
0.039	5/8	1/4	120	650	14000	13	0.21	1400	3/4	5/8
0.052	5/8	1/4	120	725	14500	18	0.22	1700	7/8	11/16
0.063	3/4	1/4	120	850	15500	22	0.24	2500	1-1/8	3/4
0.078	3/4	5/16	120	1200	19000	24	0.28	3200	1-1/4	7/8
0.093	3/4	3/8	120	1400	21000	30	0.34	4200	1-1/2	1
0.108	7/8	3/8	120	1750	20000	37	0.40	5900	1-3/4	1-1/8
0.123	7/8	3/8	120	2000	20000	42	0.48	7200	2	1-1/8

### NOTES:

1. Material must be free from dirt, grease, paint etc. prior to welding, but may have light oil.
2. Two equal metal thicknesses of each gage.
3. Commercial coating weight is 1.25 oz. per square foot.
4. Electrode Material-RWMA Group A, Class 2.
5. Water Cooling: 2 gallons per minute.

Projections should be larger in diameter for galvanized than for uncoated material.

## Projection welding galvanized low-carbon steel

Material Thickness notes 1, 2, & 3	Electrode Diameter And Shape note 4			Net Electrode Force Lb.	Welding Current (Approx.) Amps.	Weld Time Cycles	Weld Nugget Size In.	Minimum Tension-Shear Strength Lb. (For Single Projections Only)	Projection Size	
	D	d							Diameter In.	Height In.
Inches	In.	In.								
0.039	5/8	3/8	250	10000	15	0.15	925	925	0.187	0.041
0.063	5/8	7/16	400	11500	20	0.25	2050	2050	0.218	0.048
0.078	3/4	1/2	550	16000	25	0.25	2700	2700	0.250	0.054
0.093	3/4	1/2	750	18000	30	0.30	4300	4300	0.250	0.054
0.108	7/8	1/2	950	22000	33	0.31	4900	4900	0.250	0.054

### NOTES:

1. Material must be free from dirt, grease, paint etc. prior to welding, but may have light oil.
2. Two equal metal thicknesses of each gage.
3. Commercial coating weight is 1.25 oz. per square foot.
4. Electrode Material-RWMA Group A, Class 2.
5. Pressure-tight joints require stripping the zinc coating prior to welding.
6. Nominal electrode diameter ranges between 8 to 10 inches.



From American Welding Society "Recommended Practices for Resistance Welding."

## Seam welding galvanized low-carbon steel

Material Thickness notes 1, 2, & 3	Electrode Width And Shape note 4			Net Electrode Force Lb.	Welding Current (Approx.) Amps.	Weld Time		Welding Speed In./Min.	Welds Per Inch	Minimum Contacting Overlap Inches
	W	E				Heat Time Cycles	Cool Time Cycles			
Inches	In.	In.								
0.015	3/8	1/4	900	15000	2	2	120	7.5	3/8	
0.036	1/2	1/4	1100	18000	4	2	60	10.0	1/2	
0.039	1/2	1/4	1200	19000	4	3	60	9.0	1/2	
0.052	1/2	1/4	1350	20000	5	1	90	7.0	9/16	
0.063	1/2	5/16	1500	19800	8	2	54	7.0	5/8	
0.078	5/8	5/16	1850	23000	10	7	30	7.0	11/16	



**PROJECTION WELDING DATA**  
DESIGN AND WELDING DATA FOR PROJECTION WELDING LOW CARBON STEELS

Thickness of Thinnest Outside Piece Inches	PROJECTION DESIGN		ELECTRODE DIAMETERS (3/2 x Projection Diameter)		Electrode Force Pounds	Weld Time (Cycles) 60 Cycles per Sec.	Hold Time (Cycles) Minimum	Welding Current Amperes (Approx.)	Diameter of Fused Zone  D_w Inches	Minimum Shear Strength (Single Projection) (Only) (For Steels Having Strength of 100,000 psi and below) Pounds	Minimum Contacting Overlap  L Inches
	Base Diameter of Projection D_p Inches	Height of Projection H Inches	Minimum d Inches	Minimum D Inches							
0.010	0.055	0.015	0.125	1/2	50	3	3	2,800	0.112	150	1/8
0.012	0.055	0.015	0.125	1/2	80	3	3	3,100	0.112	200	1/8
0.014	0.055	0.015	0.125	1/2	100	3	3	3,400	0.112	250	1/8
0.016	0.067	0.017	0.187	1/2	115	4	4	3,600	0.112	285	5/32
0.021	0.067	0.017	0.187	1/2	150	6	6	4,000	0.140	380	5/32
0.025	0.081	0.020	0.187	1/2	200	6	8	4,500	0.140	525	3/16
0.031	0.094	0.022	0.187	1/2	300	8	8	5,100	0.169	740	7/32
0.034	0.094	0.022	0.187	1/2	350	10	10	5,400	0.169	900	7/32
0.044	0.119	0.028	0.250	5/8	480	13	14	6,500	0.169	1,080	9/32
0.050	0.119	0.028	0.250	5/8	580	16	16	7,100	0.225	1,500	9/32
0.062	0.156	0.035	0.312	7/8	750	21	20	8,400	0.225	2,100	3/8
0.070	0.156	0.035	0.312	7/8	900	24	24	9,200	0.281	2,550	3/8
0.078	0.187	0.041	0.375	7/8	1,050	26	30	10,500	0.281	2,950	7/16
0.094	0.218	0.048	0.500	7/8	1,300	32	30	11,800	0.281	3,700	1/2
0.109	0.250	0.054	0.500	7/8	1,650	38	36	13,300	0.338	4,500	5/8
0.125	0.281	0.060	0.500	7/8	1,800	45	40	15,000	0.338	5,200	11/16
0.140	0.312	0.066	0.625	1	2,300	60	45	15,700	0.437	6,000	3/4
0.156	0.343	0.072	0.625	1	2,800	80	50	17,250	0.500	7,500	13/16
0.171	0.375	0.078	0.750	1	3,300	105	50	18,600	0.562	8,500	7/8
0.187	0.406	0.085	0.750	1	3,800	125	50	20,000	0.562	10,000	15/16
0.203	0.437	0.091	0.875	1-1/4	4,500	145	55	21,500	0.625	12,000	1
0.250	0.531	0.110	1.000	1-1/4	6,800	230	60	26,000	0.687	15,000	1-1/4

**NOTES:**

- Type of Steel—Low Carbon SAE 1010—0.15% Carbon Maximum.
- Material free of scale, oxide, paint, dirt, etc.
- Size of projection determined by thickness of thinnest piece and projection should be on thickest piece.
- Data is based on thickness of thinnest sheet for two thicknesses only. Maximum ratio between two thicknesses = 3 to 1.
- See TABLE BELOW for design of punch and die for making projections.
- Contacting overlap does not include any radii from forming.
- Projection should be located in center of overlap.
- Tolerance for Projection Dimensions:

Dimension	Thickness Up to 0.050"	Thickness Over 0.050"
Diameter "D" .....	±0.003"	±0.007"
Height "H" .....	±0.002"	±0.005"

- Electrode Material:  
RWMA Class 3, Class 11 - 10 W

From American Welding Society "Recommended Practices for Resistance Welding"

**PUNCH AND DIE DESIGN FOR FORMING WELDING PROJECTIONS**

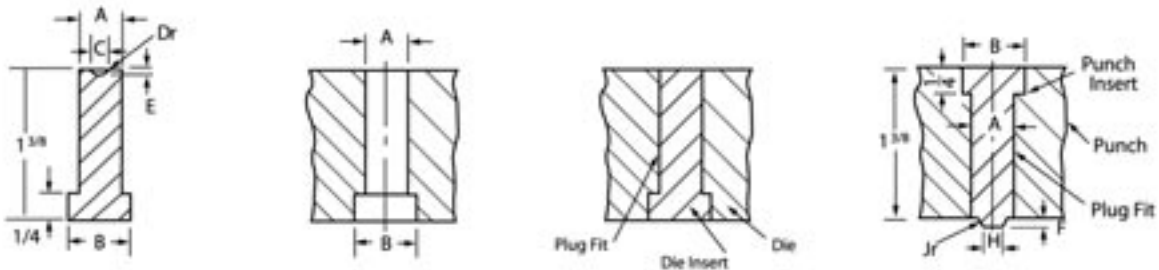

Mat Thickness	Pt. No.	A	B	±.002 C	D <sub>r</sub>	±.001 E	±.001 F	±.001 H	J <sub>r</sub>
0.010-0.015	1	3/8	9/16	.055	.033	.015	.015	.035	.005
0.016-0.021	2	3/8	9/16	.067	.042	.017	.020	.039	.005
.025	3	3/8	9/16	.081	.050	.020	.025	.044	.005
.031	4	3/8	9/16	.094	.062	.022	.030	.050	.005
.034	5	3/8	9/16	.094	.062	.022	.030	.050	.005
.044	6	3/8	9/16	.119	.078	.028	.035	.062	.005
.050	7	3/8	9/16	.119	.078	.028	.035	.062	.005
.062	8	3/8	9/16	.156	.105	.035	.043	.081	.005
.070	9	3/8	9/16	.156	.105	.035	.043	.081	.005
.078	10	3/8	9/16	.187	.128	.041	.055	.104	.010

Mat Thickness	Pt. No.	A	B	±.002 C	D <sub>r</sub>	±.001 E	±.001 F	±.001 H	J <sub>r</sub>
.094	11	1/2	11/16	.218	.148	.048	.065	.115	.010
.109	12	1/2	11/16	.250	.172	.054	.075	.137	.014
.125	13	1/2	11/16	.281	.193	.060	.085	.154	.014
.140	14	1/2	11/16	.312	.217	.066	.096	.172	.014
.156	15	5/8	13/16	.343	.243	.072	.107	.191	.014
.171	16	5/8	13/16	.375	.265	.078	.118	.210	.014
.187	17	5/8	13/16	.406	.285	.085	.130	.229	.014
.203	18	11/16	7/8	.437	.308	.091	.143	.240	.020
.250	19	13/16	1	.531	.375	.110	.175	.285	.025

Material: Tool Steel. Finish all over and harden to 65-68 Rockwell "C" scale. Note: All working surfaces of die unit must be polished.

From American Welding Society "Recommended Practices for Resistance Welding"



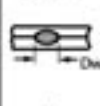

**SCHEDULE FOR SPOT WELDING STAINLESS STEEL**

THICKNESS "T" OF THINNEST OUTSIDE PIECE (See Notes 1, 2, 3 and 4 Below)	ELECTRODE DIAMETER AND SHAPE (See Note 5)		ELECTRODE FORCE LB.	WELD TIME CYCLES (60 Per Sec.)	WELDING CURRENT (Approx.) AMPS		MINIMUM CONTACTING OVERLAP 	MINIMUM WELD SPACING (See Note 6 Below)	DIAMETER OF FUSED ZONE 	MINIMUM SHEAR STRENGTH LB.					
	D, IN. Min.	d, IN. Max.			Tensile Strength Below 150000 Psi	Tensile Strength 150000 Psi and Higher				IN.	IN.	IN. Approx.	Ultimate Tensile Strength of Metal		
													70000 Up to 90000 Psi	90000 Up to 150000 Psi	150000 Psi and Higher
	INCHES														
0.006	3/16	3/32	180	2	2000	2000	3/16	3/16	0.045	60	70	85			
0.008	3/16	3/32	200	3	2000	2000	3/16	3/16	0.065	150	170	210			
0.012	1/4	1/8	260	3	2100	2000	1/4	1/4	0.076	185	210	250			
0.014	1/4	1/8	300	4	2500	2200	1/4	1/4	0.082	240	250	320			
0.016	1/4	1/8	330	4	3000	2500	1/4	5/16	0.088	280	300	380			
0.018	1/4	1/8	380	4	3500	2800	1/4	5/16	0.093	320	360	470			
0.021	1/4	5/32	400	4	4000	3200	5/16	5/16	0.100	370	470	500			
0.025	3/8	5/32	520	5	5000	4100	3/8	7/16	0.120	500	600	680			
0.031	3/8	3/16	650	5	6000	4800	3/8	1/2	0.130	680	800	930			
0.034	3/8	3/16	750	6	7000	5500	7/16	9/16	0.150	800	920	1100			
0.040	3/8	3/16	900	6	7800	6300	7/16	5/8	0.160	1000	1270	1400			
0.044	3/8	3/16	1000	8	8700	7000	7/16	1 1/16	0.180	1200	1450	1700			
0.050	1/2	1/4	1200	8	9500	7500	1/2	3/4	0.190	1450	1700	2000			
0.056	1/2	1/4	1350	10	10300	8300	9/16	7/8	0.210	1700	2000	2450			
0.062	1/2	1/4	1500	10	11000	9000	5/8	1	0.220	1950	2400	2900			
0.070	5/8	1/4	1700	12	12300	10000	5/8	1-1/8	0.250	2400	2800	3550			
0.078	5/8	5/16	1900	14	14000	11000	1 1/16	1-1/4	0.275	2700	3400	4000			
0.094	5/8	5/16	2400	16	15700	12700	3/4	1-1/2	0.290	3550	4200	5300			
0.109	3/4	3/8	2800	18	17700	14000	13/16	1-1/2	0.290	4200	5000	6400			
0.125	3/4	3/8	3300	20	18000	15500	7/8	2	0.300	5000	6000	7600			

**NOTES:**

- Types of Steel—301, 302, 303, 304, 308, 309, 310, 316, 317, 321, 347 & 349
- Material should be free from scale, oxides, paint, grease and oil.
- Welding conditions determined by thickness of thinnest outside piece "T".
- Data for total thickness of pile-up not exceeding 4 "T". Maximum ratio between two thicknesses 3 to 1.
- Electrode material, RWMA Class 2, Class 3, or Class 11.
- Minimum weld spacing is that spacing for two pieces for which no special precautions need be taken to compensate for shunted current effect of adjacent welds. For three pieces increase spacing 30 per cent.

**SCHEDULE FOR SEAM WELDING STAINLESS STEEL**

THICKNESS "T" OF THINNEST OUTSIDE PIECE (See Notes 1, 2, 3 and 4 Below)	ELECTRODE WIDTH AND SHAPE (See Note 5 Below)	ELECTRODE FORCE LB.	ON TIME CYCLES (60 Per Sec.)	OFF TIME FOR MAXIMUM SPEED (Pressure-Tight)		MAXIMUM WELD SPEED		WELDS PER INCH		WELDING CURRENT (Approx.) AMPS.	MINIMUM CONTACTING OVERLAP (See Note 6 Below)
				CYCLES		IN. PER MINUTE		PER INCH			
				2 "T"	4 "T"	2 "T"	4 "T"	2 "T"	4 "T"		
				INCHES	W, IN., Min.						
0.006	3/16	300	2	1	1	60	67	20	18	4000	1/4
0.008	3/16	350	2	2	2	67	56	18	16	4600	1/4
0.010	3/16	400	3	2	2	45	51	16	14	5000	1/4
0.012	1/4	450	3	2	2	48	55	15	13	5600	5/16
0.014	1/4	500	3	2	3	51	46	14	13	6200	5/16
0.016	1/4	600	3	2	3	51	50	14	12	6700	5/16
0.018	1/4	650	3	2	3	55	50	13	12	7300	5/16
0.021	1/4	700	3	2	3	55	55	13	11	7900	3/8
0.025	3/8	850	3	3	4	50	47	12	11	9200	7/16
0.031	3/8	1000	3	3	4	50	47	12	11	10600	7/16
0.040	3/8	1300	3	4	5	47	45	11	10	13000	1/2
0.050	1/2	1600	4	4	5	45	44	10	9	14200	5/8
0.062	1/2	1850	4	5	7	40	41	10	8	15100	5/8
0.070	5/8	2150	4	5	7	44	41	9	8	15900	1 1/16
0.078	5/8	2300	4	6	7	40	41	9	8	16500	1 1/16
0.094	5/8	2550	5	6	7	38	38	9	8	16600	3/4
0.109	3/4	2950	5	7	9	38	37	8	7	16800	13/16
0.125	3/4	3300	6	6	8	38	37	8	7	17000	7/8

**NOTES:**



- Types of Steel—301, 302, 303, 304, 308, 309, 310, 316, 317, 321, 347 & 349.
- Material should be free from scale, oxides, paint, grease and oil.
- Welding conditions determined by thickness of thinnest outside piece "T".
- Data for total thickness of pile-up not exceeding 4 "T". Maximum ratio between two thicknesses 3 to 1.
- Electrode material, RWMA Class 3.
- For large assemblies minimum contacting overlap indicated should be increased 30 per cent.

From American Welding Society "Recommended Practices for Resistance Welding"

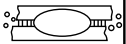
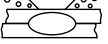
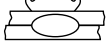
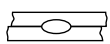

# Weld Defects and Causes

This chart is intended only as a check list of the possible causes of some of the more common weld defects. The data shown should be used only as guide and applies basically to two equal thicknesses of mild steel.

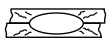
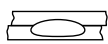
AREA OF CAUSE	POSSIBLE CAUSE OF WELD DEFECT	TYPE OF DEFECT							
		EXPULSION AT WELD INTERFACE 	SURFACE EXPULSION ELECTRODE STICKING 	ELETRODE MUSHROOM 	LOW WELD STRENGTH 	EXCESSIVE WELD INDENTATION 	INTERNAL CRACKS IN WELD NUGGET 	CRACKS IN PARENT METAL 	DISPLACE WELD NUGGET 
WELDING CONDITIONS	SQUEEZE TIME – Short	X	X						
	WELD TIME	Short				X			
		Long		X	X		X	✓	
	HOLD TIME – Short		X		✓		X	✓	
	WELD FORCE	Low	X	X	X		✓	X	
		High			✓	X	X		X
	WELD CURRENT	Low				X			
		High	✓	X	X		X		
	ELECTRODE FACE AREA	Small			X	X	✓		✓
		Large				✓		✓	
ELECTRODES MISALIGNED		✓						X	
INSUFFICIENT COOLING				✓		✓		X	
POOR HEAT BALANCE			✓		X			X	
CONDUCTIVITY ELECTRODE MATERIAL	Low		✓	✓					
	High							✓	
PARTS WELDED	DIRTY-SCALEY MATERIAL	X	X		✓		X		
	POOR FIT UP	X			✓	X		X	
	INSUFFICIENT EDGE DISTANCE	X	✓		✓	✓			
	WELDS TOO CLOSE TOGETHER				X				
	METALLURGY OF MATERIAL WELDED	✓	✓		✓	✓	X	X	
MISCELLANEOUS	POOR HEAD FOLLOW-UP	✓	✓			✓	X		
	WELDER HEAD IMPACTS WORK			X		X			
	POOR VOLTAGE REGULATION	✓	✓						
	POOR AIR PRESSURE REGULATION	✓	✓						

NOTE: Causes Considered Individually

**X** = MORE PREVALENT

**✓** = LESS PREVALENT



Many factors affecting electrode cost and useful electrode life are briefly outlined below.

## PART TO BE WELDED

Lay out the part for resistance welding. Designing engineer, welding engineer and production man in charge of welding should cooperate in securing a better product at lowest cost.

Correct design permits the use of standard straight electrodes: or standard offset or standard angular holders if the straight approach is not possible. Special shaped electrodes cost more, and the difficulty of cooling the electrode is amplified. Single spot, multiple spot, projection, or other method may be accurately chosen to achieve lowest cost. Consult the R.W.M.A Manual.\* PN: RWMA-BOOK

## MATERIAL TO BE WELDED

The weldability of the materials can be determined by consulting your material supplier, and by reviewing recommendations covered in the R.W.M.A Manual.\*

Surface conditions, rust, oil, dirt, and, on many articles, oxide film and even handling marks have a decided effect on weld quality. Cleaning may have to be a part of the welding job in some cases.

## WELDING EQUIPMENT AND CONTROL

A welding machine of reputable quality purchased for a particular application will be correctly designed both electrically and mechanically, and will be supplied the correct control equipment and electrodes for the work.

On machine change-overs make sure of adequate electrical and mechanical capacity, and see that the necessary controls are provided. Consult us when redesigning or revising your choice of electrodes.

The RWMA tip numbering system has generally replaced the old Morse taper numbers with new "RW" numbers, and has added two new sizes, as the chart illustrates.

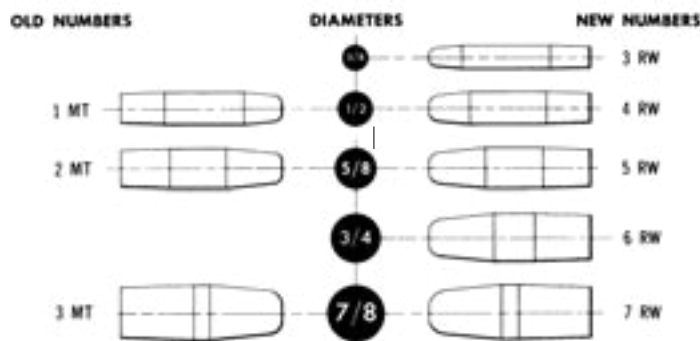

## ELECTRODE LIFE SAVERS

1. Use standard Tuffaloy electrodes with Tuffaloy ejector type, self-adjusting tube, water-cooled electrode holders wherever possible. Avoid special or irregular shapes for lowest cost.
2. Use ample cold cooling water as close as practical to the welding contact surface, properly circulated at a minimum of 30-psi pressure, and supplied at a rate of at least 1-1/2 gallons per minute.
3. Be sure to select the proper type and size of electrode, taking into consideration electrode pressure, contact area of electrode, gauge, and nature of material to be welded. Consult the RWMA Manual\* or your Tuffaloy field engineer regarding recommended practices. Overloading as well as overheating shortens electrode life.
4. Good welds depend upon properly maintained electrodes which assure an accurate surface contact. Keep tapers clean and dress electrode faces with lathe, emery paddle or fine file. Use castor oil or graphite grease to facilitate tip removal, and avoid application of insulators such as teflon tape and other materials.

## STANDARD GAGE CHART

Thickness in Decimals of an Inch

Gage No.	Manufacturer's Standard	Gage No.	Manufacturer's Standard	Gage No.	Manufacturer's Standard
3	0.2391	12	0.1046	22	0.0299
4	0.2242	13	0.0897	23	0.0269
5	0.2092	14	0.0747	24	0.0239
6	0.1943	15	0.0673	25	0.0209
7	0.1793	16	0.0598	26	0.0179
8	0.1644	17	0.0538	27	0.0164
9	0.1495	18	0.0478	28	0.0149
10	0.1345	19	0.0418	29	0.0135
11	0.1196	20	0.0359	30	0.0120
		21	0.0329		

\* Resistance Welding Manual, published by the Resistance Welder Manufacturers Association. PN: RWMA-BOOK

## RESISTANCE WELDING MACHINE SETUP

### TO DETERMINE SPOT WELDING SCHEDULE

$$\begin{aligned} \text{CURRENT} &= 2T \times 100,000 = \text{AMPERES} \\ \text{TIME} &= 2T \times 100 = \text{CYCLES} \\ \text{PRESSURE} &= 2T \times 6000 \text{ (LB)} = \text{FORCE REQUIRED (LB)} \\ T &= \text{THICKNESS OF THE THINNEST PIECE} \end{aligned}$$

### APPROXIMATE PRESSURE EXERTED BY AIR CYLINDER SIZE

DIAMETER	CYLINDER AREA		
	SQ. INCHES		
4"	= 12.5	x WELDER	= ELECTRODE
5"	= 19.5	x GUAGE	= FORCE
6"	= 28.0	x PRESSURE	= PRESSURE
8"	= 50.0	x	





## RESISTANCE WELDING

## DO'S

- Use the RWMA recommended electrode material for the job you are running.
- Use RWMA standard electrodes whenever possible.
- Use the appropriate electrode diameter for the material being welded.
- Use open sight drains or have water flow gauges on out bound side to easily confirm water flow.
- Connect the water inlet hose to the proper holder inlet to insure water flows through the center cooling tube first.
- Recommended water flow for the electrodes is 1.5 gallons per minute of cold water.
- Insure that the water tube extends within 0.25" of the bottom of the electrode water hole.
- Adjust the water tube position when changing to another length electrode.
- Check water tube ends to insure they are not damaged and have an angled cut at the end to prevent water restriction.
- Use ejector type holders to simplify electrode removal.
- Keep the electrode and holder tapers clean to ensure good leak free conduction.
- Dress electrodes frequently to insure good quality welds.
- Dress electrodes in a lathe to their original contour whenever possible.
- Use raw-hide or hard rubber hammers for alignment of electrodes.
- Provide cooling water on the exit side top and bottom of seam welding applications.
- Use properly designed knurling wheels to insure continuous dressing of the seam welding wheel.
- Lock out the machine when performing any type of maintenance.

## DON'TS

- Never use unidentified electrodes or materials.
- Avoid special, offset, or irregular electrodes when the job can be done with standard electrodes.
- Do not use small electrodes on heavy gauge welding jobs or large electrodes on small gauge materials.
- Do not forget to turn the water on full force before starting to weld.
- Never use water hoses that do not fit the water fitting properly.
- Do not allow water connections to become leaky, clogged or broken.
- Avoid holders with leaking or deformed tapers.
- Never use holders that do not have adjustable water deflector tubes.
- Never use pipe tape or similar product to stop a leak.
- Do not let your electrode mushroom excessively.
- Do not dress electrodes with a file.
- Do not use a steel hammer to adjust any part of a welding machine.
- Avoid the use of seam welder wheels too thin to stand the heat or pressure of your job.
- Do not permit seam welding wheels to run off the edge of the work piece.
- Do not enter a work cell or reach into a welder without using your lockout.



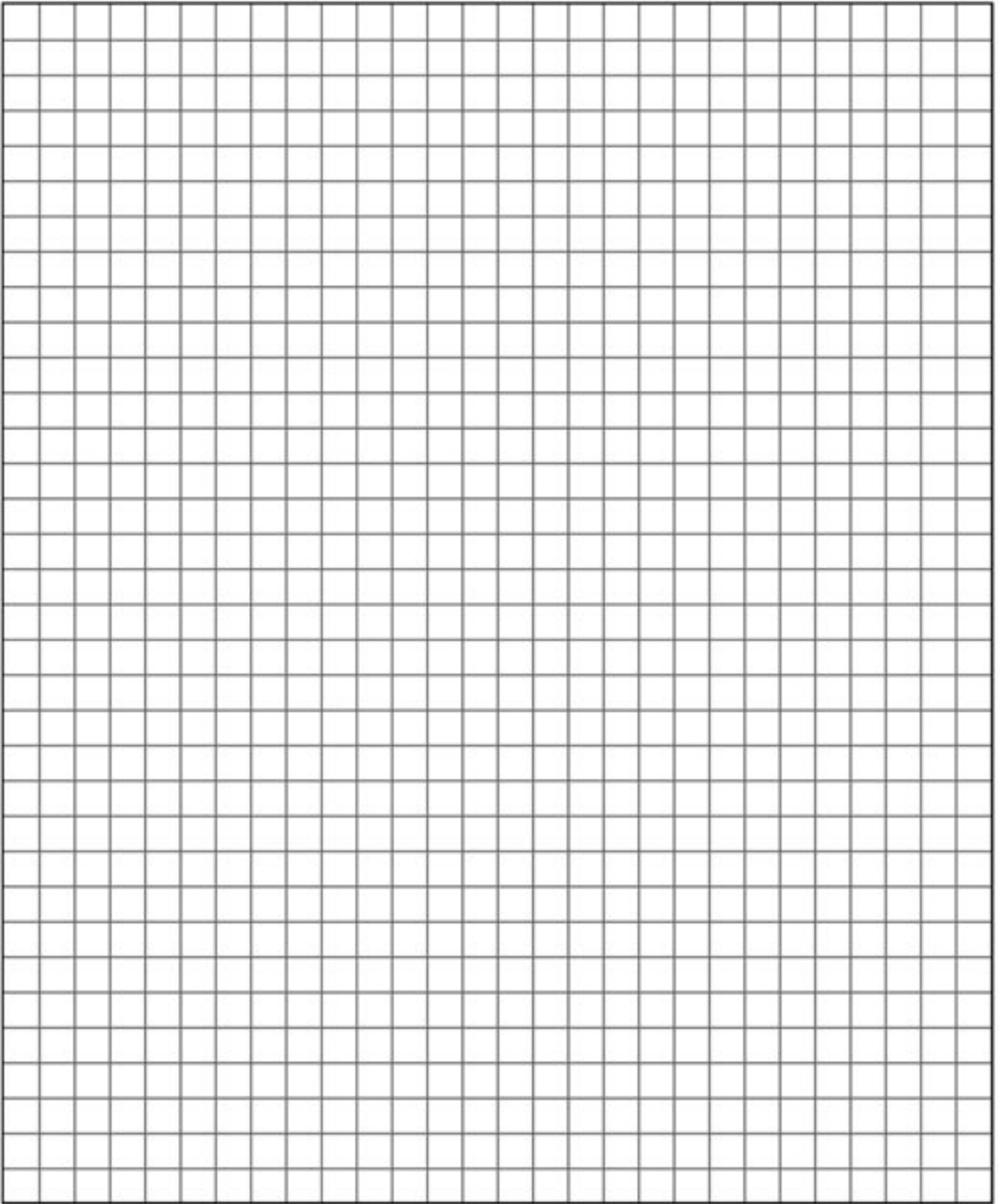

# QUOTE REQUEST SPECIALS AND CUSTOMS

Contact Name: \_\_\_\_\_ Company: \_\_\_\_\_

Address: \_\_\_\_\_

Phone: \_\_\_\_\_ Fax: \_\_\_\_\_ Email: \_\_\_\_\_

Part Information: \_\_\_\_\_ Material/Alloy: \_\_\_\_\_

Part Number or Description: \_\_\_\_\_

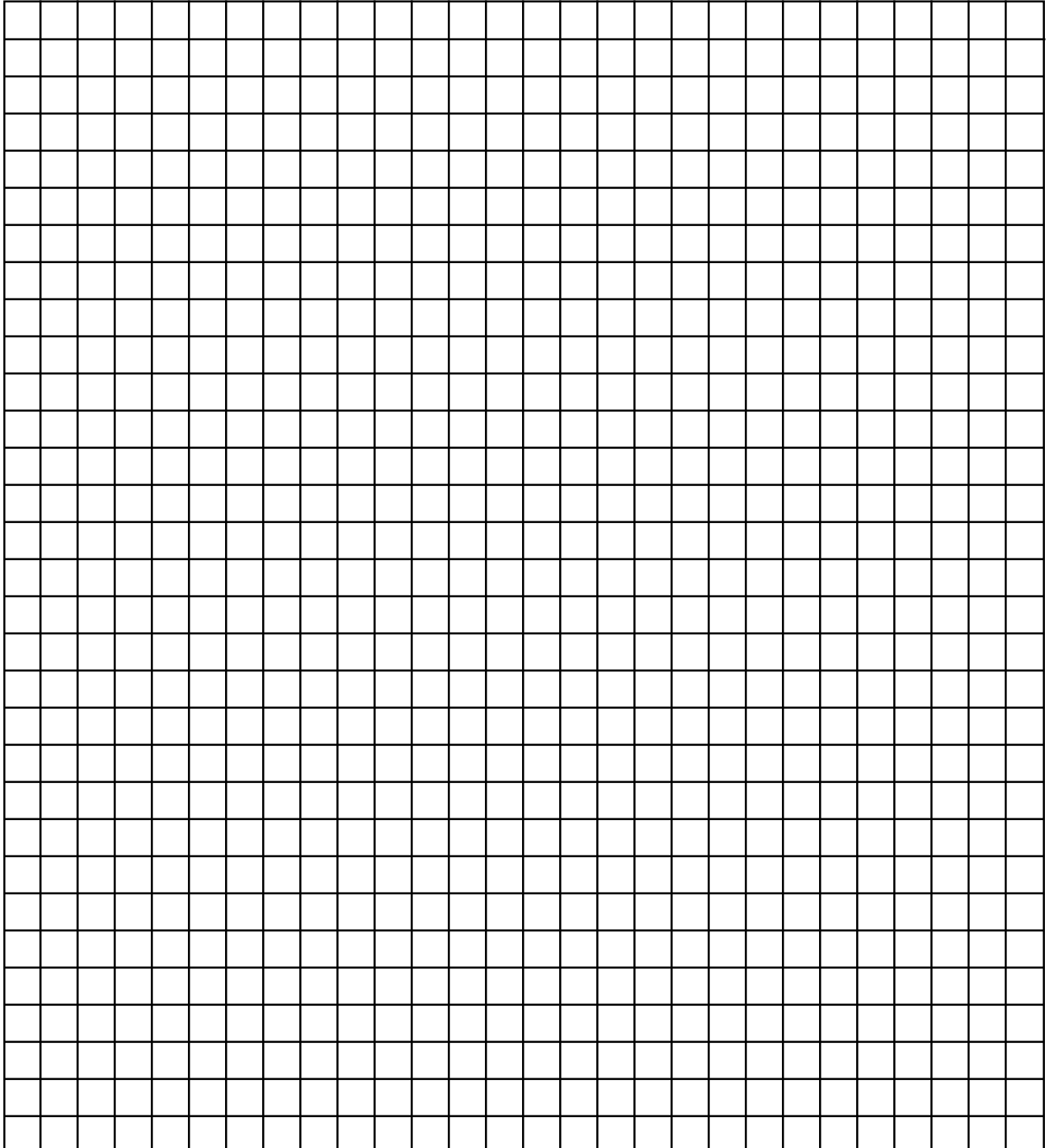

Please send a photo of part laying on the grid area of this completed page to – [customerservice@tuffaloy.com](mailto:customerservice@tuffaloy.com)



1400 South Batesville  
Greer, South Carolina 29650



Phone: (864) 879-0763 | Fax: (864) 877-2212



Email: [tuffaloy@tuffaloy.com](mailto:tuffaloy@tuffaloy.com)



[www.tuffaloy.com](http://www.tuffaloy.com)



9720 Middle Line  
Blenheim, Ontario, Canada



Phone: (519) 676-8173 | Fax: (519) 676-3329  
Toll Free: 1-800-265-5262



Email: [tuffaloy@tuffaloy.com](mailto:tuffaloy@tuffaloy.com)



[www.tuffaloy.com](http://www.tuffaloy.com)

## DISCLAIMER AND LIMITED WARRANTY

Tuffaloy Products, Inc. represents that the products described in this catalog will conform to the specifications contained in the catalog, but extends no warranty with respect to the products. NEITHER TUFFALOY PRODUCTS, INC. NOR ANY PERSON ON TUFFALOY PRODUCTS, INC.'S BEHALF HAS MADE OR MAKES ANY EXPRESS OR IMPLIED REPRESENTATION OR WARRANTY WHATSOEVER, EITHER ORAL OR WRITTEN, INCLUDING ANY WARRANTIES OF MERCHANTABILITY, FITNESS FOR A PARTICULAR PURPOSE, TITLE, OR NON-INFRINGEMENT OR PERFORMANCE OF THE PRODUCTS DESCRIBED IN THIS CATALOG TO STANDARDS SPECIFIC TO THE COUNTRY OF IMPORT, WHETHER ARISING BY LAW, COURSE OF DEALING, COURSE OF PERFORMANCE, USAGE OF TRADE OR OTHERWISE, ALL OF WHICH ARE EXPRESSLY DISCLAIMED. If Tuffaloy determines in its sole judgement that a product described in this catalog does not conform to the specifications, then Tuffaloy will, upon return of the product to Tuffaloy, Freight prepaid, make a reasonable adjustment to the original purchase price or, at Tuffaloy's option, repair or replace the nonconforming product, F.O.B. Tuffaloy's facility.

IN NO EVENT SHALL TUFFALOY PRODUCTS, INC. OR ITS REPRESENTATIVES BE LIABLE FOR CONSEQUENTIAL, INDIRECT, INCIDENTAL, SPECIAL, EXEMPLARY, PUNITIVE OR ENHANCED DAMAGES, LOST PROFITS OR REVENUES OR DIMINUTION IN VALUE, ARISING OUT OF OR RELATING TO ANY CLAIMS RELATED TO THE PRODUCTS DESCRIBED IN THIS CATALOG, REGARDLESS OF (A) WHETHER SUCH DAMAGES WERE FORESEEABLE, (B) WHETHER OR NOT BUYER WAS ADVISED OF THE POSSIBILITY OF SUCH DAMAGES AND (C) THE LEGAL OR EQUITABLE THEORY (CONTRACT, TORT OR OTHERWISE) UPON WHICH THE CLAIM IS BASED, AND NOTWITHSTANDING THE FAILURE OF ANY AGREED OR OTHER REMEDY OF ITS ESSENTIAL PURPOSE. Although Tuffaloy believes the information contained in this catalog to be accurate, it does not extend, and hereby disclaims, any warranty that such information is accurate and complete. Tuffaloy reserves the right to change any specifications or other information in this catalog without notice.